

**EBA Tipper Pump (2016) - EBA xxx30**

Technical Specification

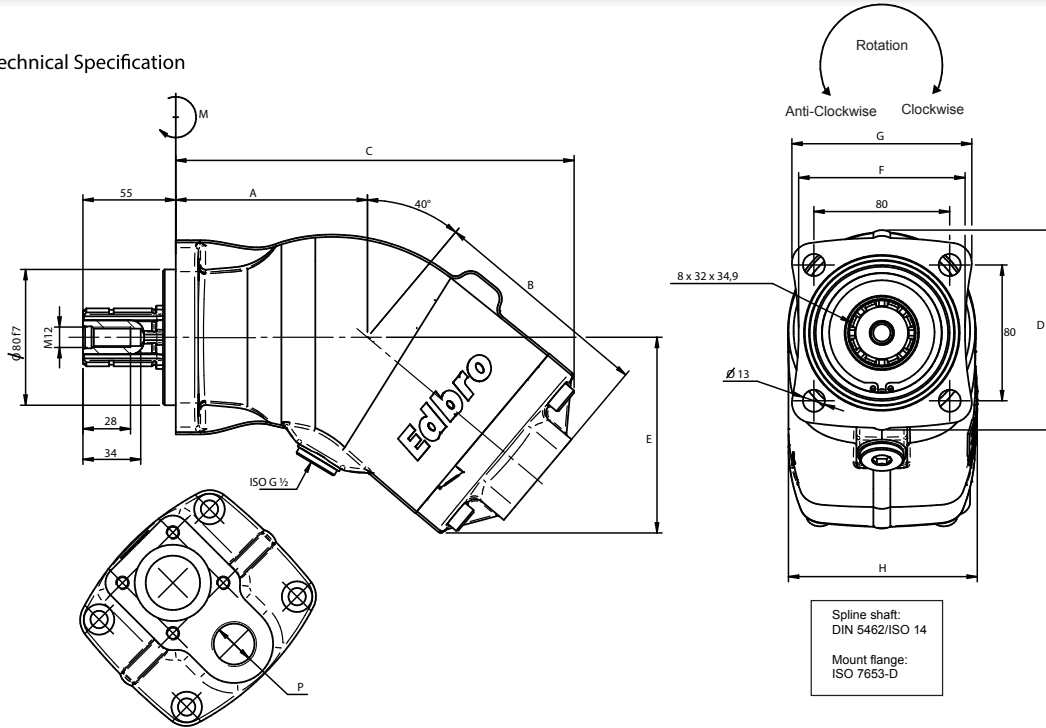

Part Code:  
EBA /xxx/30/#

xxx - Choose from below (Pump Flow)

047      064      090      130

Theoretical oil flow l/min at pump speed	rpm	500	23.5	31.8	45.0	65.0
		1000	47.1	63.6	90.0	130.0
		1500	70.6	95.4	135.0	195.0
Displacement	cm <sup>3</sup> /rev		47.1	63.6	90.0	195.0
Max pump speed						
continuous	rpm		1900	1900	1500	1500
limited			2500	2500	2000	2000
Max working pressure	bar		300	300	300	300
Weight	kg		9.8	9.8	9.8	13.9
Dimensions	mm	A	113	113	113	122
		B	131	131	131	147
		C	235	235	235	264
		D	118	118	118	127
		E	115	115	115	133
		F	98	98	98	98
		G	106	106	106	106
		H	111	111	111	118
		ISO G	P	34	34	34
Self-weight moment (M)	Nm	6.0	11.5	11.5	11.5	18.0

xxx - Pump Flow cc/rev  
30 - 300 bar

# - Direction of Rotation - Part codes ending in (C) will refer to Clockwise rotation, (A) will refer to Anti-clockwise rotation.

For installation and oil recommendations please refer to the General Instructions document. [www.technical.edbro.com](http://www.technical.edbro.com)