

Double acting cylinder 2 stage with spheric bearings

CD11SS2001201BA11053

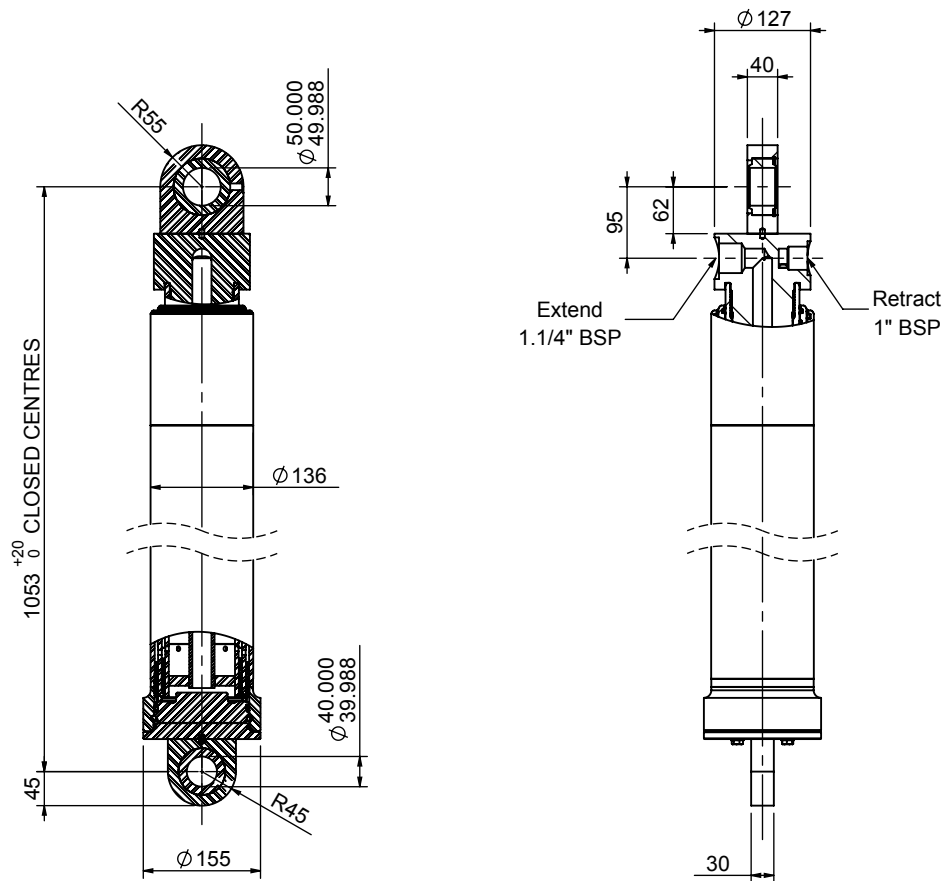

SPECIFICATION

Stage	Tube Diameter	Tube Bore	Length	Stroke	Swept Volume (Extend)	Swept Volume (Retract)
Base	136	125	836	-	-	-
1	117	106	802	598	7.3	0.9
2	98	87	827	603	5.3	1.5
Total (+5/-10)				1201	mm	
Swept Vol (Extend)				12.6	Litres	
Swept Vol (Retract)				2.4	Litres	
Maximum Pressure				190	Bar	
Operating Pressure				175	Bar	
Cylinder Mass				62	kg	
Stage	Thrust @ Max.Press		Thrust @ Op.Press			
	Extend	Retract	Extend	Retract		
1	23.8	2.9	21.9	2.7		
4	17.1	2.5	15.7	2.3		

NOTES

- This cylinder is intended for load ejection purposes only and should not be used for compacting.
- Cylinder is painted in primer to RAL5013.
- Refer to www.edbro.com for:-
 - Bracket details
 - Installation instructions that must be observed
 - Correct oil selection
 - An explanation of ejection capacity

INNER TUBES HARD CHROMED



JOST UK Ltd
 Edbro House, Nelson Street, Bolton, England, BL3 2JJ
 Tel +44 (0) 1204 528888 Fax +44 (0) 1204 531957
 Email: sales@jost-world.com Web: www.edbro.com

Technical Specifications are subject to change without notice
 Date Created/Updated: 24 July 2019
 Refer www.edbro.com to confirm latest specification
 All dimensions are in 'mm', unless otherwise stated