

Cylinder 2 stage with spherical eyes

CD15SS2001877EB11484B

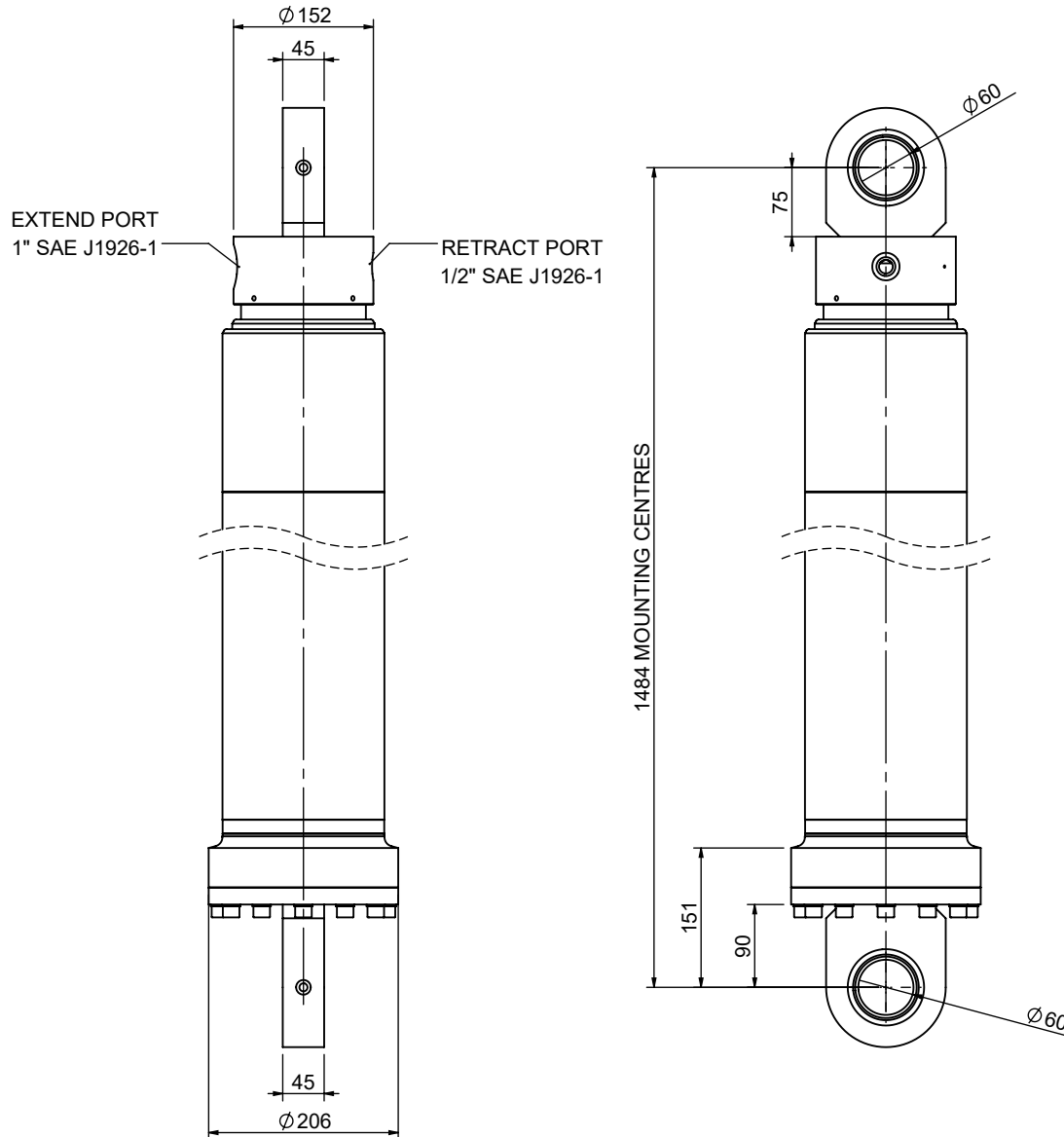

SPECIFICATION

Stage	Tube Diameter	Tube Bore	Length	Stroke	Swept Volume (Extend)	Swept Volume (Retract)
Base	176	163	1200	-	-	-
1	155	144	1190	956	20.0	1.9
2	136	125	1210	921	15.0	1.6
Total (+5/-10)				1877	mm	
Final stroke reduced by				50	mm	
Swept Vol (Extend)				35	Litres	
Swept Vol (Retract)				3.5	Litres	
Maximum Pressure				190	Bar	
Operating Pressure				175	Bar	
Cylinder Mass				123.78	kg	
Stage	Thrust @ Max.Press		Thrust @ Op.Press			
	Extend	Retract	Extend	Retract		
1	40.4	3.9	37.2	3.6		
2	31.5	3.4	29.1	3.1		

NOTES

- This cylinder is intended for load ejection purposes only and should not be used for compacting.
- Cylinder is painted in primer to RAL5013.
- Refer to www.edbro.com for:-
 - Bracket details
 - Installation instructions that must be observed
 - Correct oil selection
 - An explanation of ejection capacity

ALL TUBES HARD CHROMED



Edbro Hydraulics Ltd.
 Edbro House, Nelson Street, Bolton, England, BL3 2JJ
 Tel +44 (0) 1204 528888 Fax +44 (0) 1204 531957
 Email: sales@edbro.com Web: www.edbro.com

Technical Specifications are subject to change without notice
 Date Created/Updated: 12 May 2022
 Refer www.edbro.com to confirm latest specification
 All dimensions are in 'mm', unless otherwise stated