

Cylinder 7 stage front end with spherical eye

CD22TS7408986BA10876

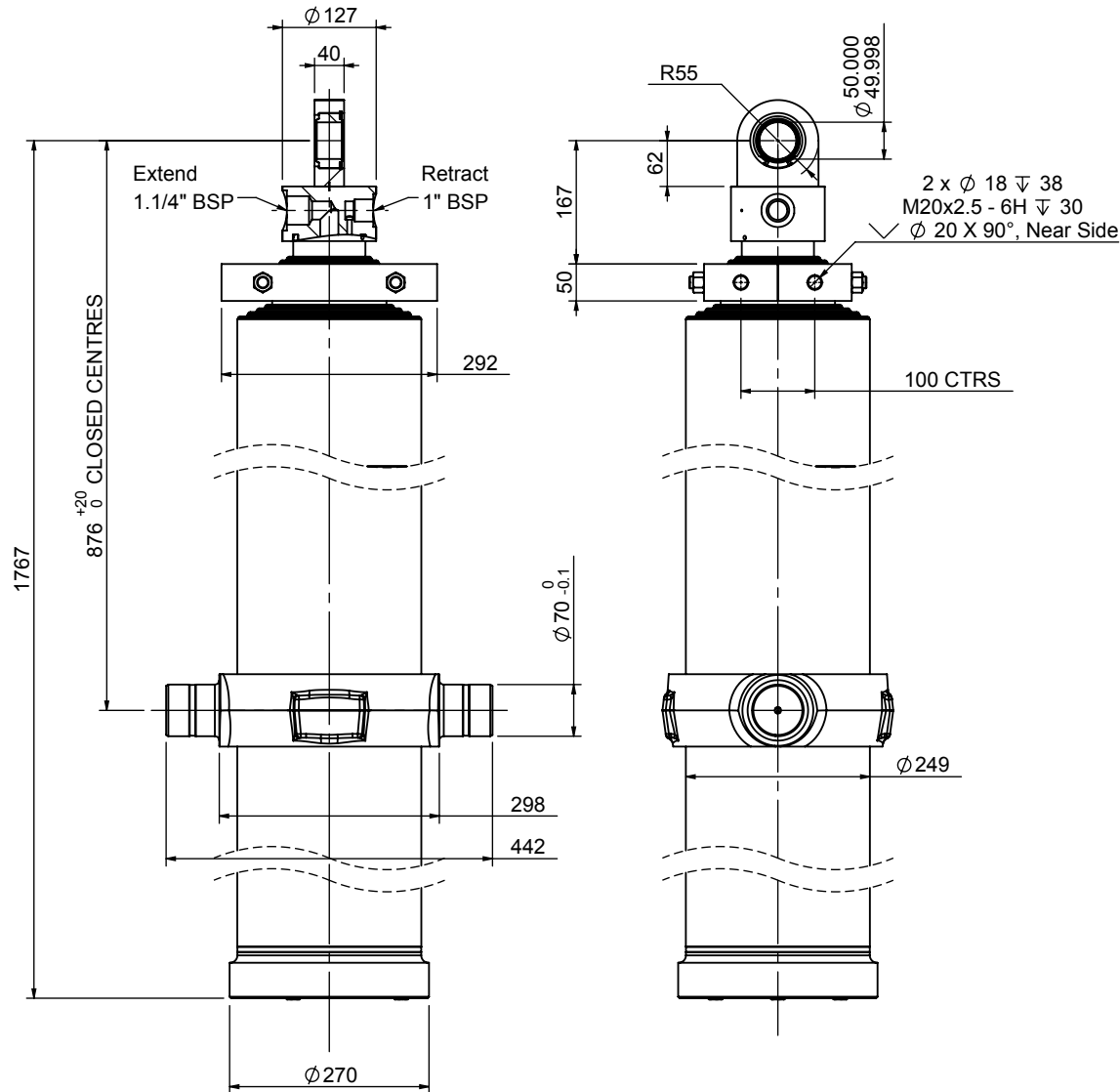

SPECIFICATION

Stage	Tube Diameter	Tube Bore	Length	Stroke	Swept Volume (Extend)	Swept Volume (Retract)
Base	249	230	1529	-	-	-
1	222	206	1490	1234	51.3	3.5
2	198	184	1490	1242	41.4	3.2
3	176	163	1490	1251	33.3	2.8
4	155	144	1540	1261	26.3	2.5
5	136	125	1540	1321	21.5	2.3
6	116	106	1540	1336	16.4	2.3
7	98	87	1565	1341	11.8	1.7
Total (+5/-10)				8986	mm	
Swept Vol (Extend)				202	Litres	
Swept Vol (Retract)				18.3	Litres	
Maximum Pressure				190	Bar	
Operating Pressure				135	Bar	
Cylinder Mass				431	Kg	
Stage	Thrust @ Max.Press		Thrust @ Op.Press			
	Extend	Retract	Extend	Retract		
1	80.5	5.5	57.2	3.9		
2	64.6	4.9	45.9	3.5		
3	51.5	4.4	36.6	3.1		
4	40.4	3.9	28.7	2.7		
5	31.5	3.4	22.4	2.4		
6	23.8	3.3	16.9	2.3		
7	17.1	2.5	12.1	1.8		

NOTES

- This cylinder is intended for load ejection purposes only and should not be used for compacting.
- Cylinder is painted in primer to RAL5013.
- Refer to www.edbro.com for:-
 - Bracket details
 - Installation instructions that must be observed
 - Correct oil selection
 - An explanation of ejection capacity

INNER TUBES HARD CHROMED

Edbro

JOST UK Ltd
 Edbro House, Nelson Street, Bolton, BL3 2JJ, UK
 Tel +44 (0) 1204 528888 Fax +44 (0) 1204 531957
 Email: sales@jost-world.com Web: www.edbro.com

Technical Specifications are subject to change without notice
 Date Created/Updated: 12 February 2021
 Refer www.edbro.com to confirm latest specification
 All dimensions are in 'mm', unless otherwise stated