

# Cylinder 3 stage front end with Outer Cover

**\*\*ALLOW 50mm TO REMOVE CAP FOR SERVICING**

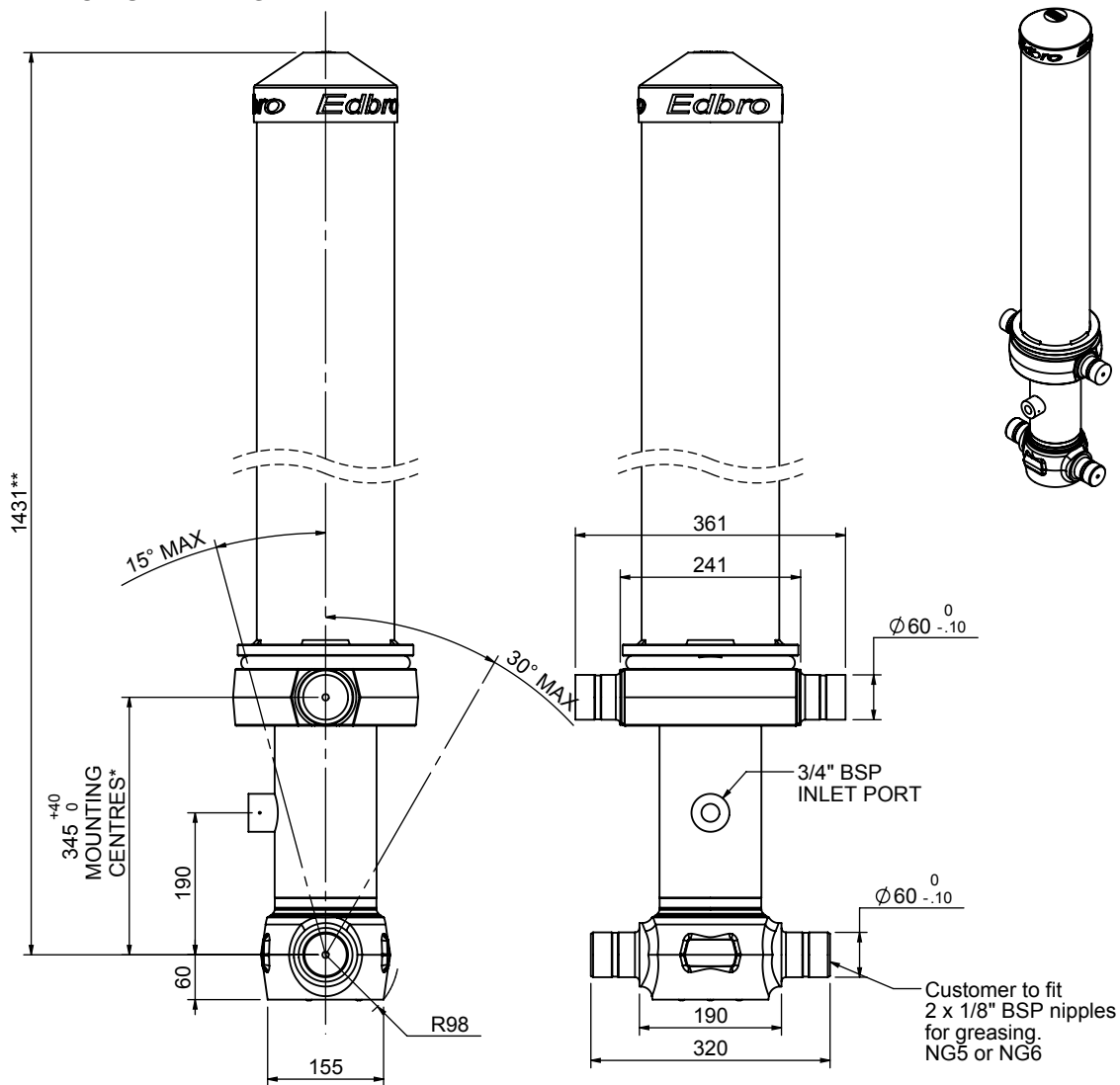

**\*Include 14mm Pull Out**

## CS110033494B19A11

SPECIFICATION		RATED CAPACITY : 22-35 TONNES***		
Stage	Diameter	Length	Stroke	Swept Volume
-	-	-	-	-
-	-	-	-	-
OUTER COVER	184	1035	-	-
0	136	1375	-	-
1	117	1340	1149	12
2	98	1340	1167	9
3	79	1340	1172	6
Final stroke reduced by	0	Total (+5/-10)	3488	27
Cylinder Mass (Kg)	116.10	Priming Volume	9.6	
Rated Pressure (Bar)	150	Total Volume (Litres)	36.6	
Maximum Pressure (Bar)	175	Max. first stage thrust	130 KN	

### \*\*\*TIPPING CAPACITY AT RATED PRESSURE

$d = 178 ; r = 750$

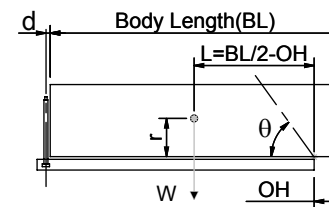

BODY LENGTH (BL)						OH
4500		4625		4750		
23	46°	23	44°	22	43°	150
28	49°	27	48°	26	46°	450
		35	52°	33	50°	750

Tipping angle ( $\theta$ )  
 Body + payload mass, W (tonne)

### For guidance only;

Higher Rated Pressures may be possible. To check your application, email Edbro plc at <applications@edbro.co.uk>

### NOTES

- If hydraulic pressure is used to limit overloading, the system relief valve must be set to the Rated Pressure unless agreed otherwise by Edbro
- The system relief valve can be set to Maximum Pressure if the load is limited by other means. See RATINGS page for advice
- This cylinder is for lifting purposes only and sload conditions must be avoided
- Cylinder is painted in primer paint to RAL5013
- See bracket options page BRKT01, BRKT02
- See installation instructions INSTALL01
- Use oil according to specification OIL01

**Edbro**  
SETTING THE INDUSTRY STANDARD

**Edbro plc**  
Nelson Street, Bolton, Lancashire BL3 2JJ UK  
Tel +44 (0) 1204 528888 Fax +44 (0) 1204 531957  
Email: postmaster@edbro.com Web: www.edbro.com

Technical Specifications are subject to change without notice  
Date Created/Updated: 16 February 2011 14:09:37  
Refer www.edbro.com to confirm latest specification  
All dimensions are in 'mm', unless otherwise stated