

Cylinder 4 stage front end with Outer Cover

****ALLOW 50mm TO REMOVE CAP FOR SERVICING**

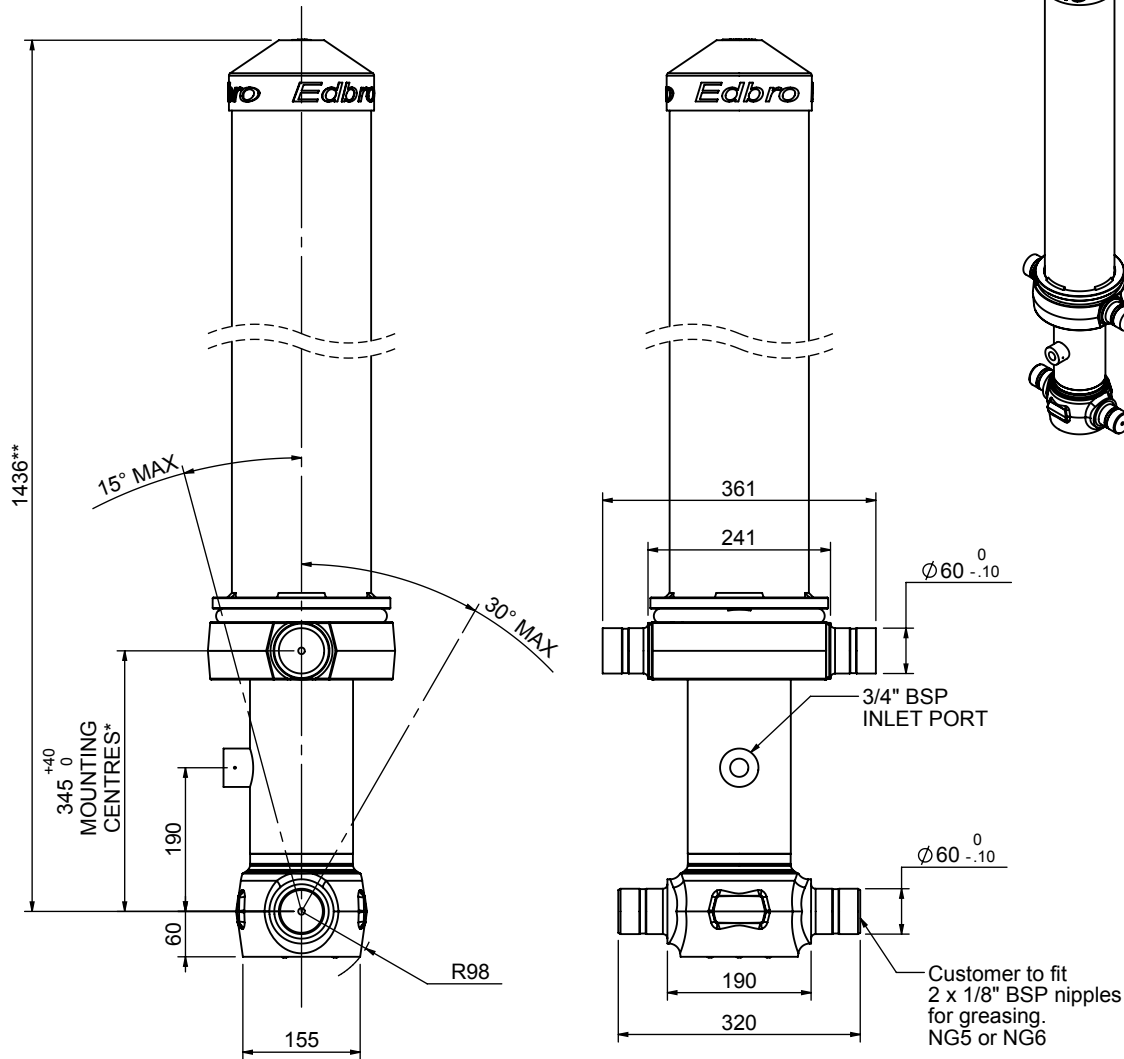

CS110044671B19A11

SPECIFICATION		RATED CAPACITY : 16-25 TONNES***		
Stage	Diameter	Length	Stroke	Swept Volume
-	-	-	-	-
OUTER COVER	184	1040	-	-
0	136	1375	-	-
1	117	1340	1149	12
2	98	1340	1167	9
3	79	1340	1172	6
4	63	1340	1177	4
Final stroke reduced by	0	Total (+5/-10)	4665	31
Cylinder Mass (Kg)	131.06	Priming Volume	8.7	
Rated Pressure (Bar)	175	Total Volume (Litres)	39.7	
Maximum Pressure (Bar)	175	Max. first stage thrust	130 KN	

***TIPPING CAPACITY AT RATED PRESSURE

$d = 178 ; r = 750$

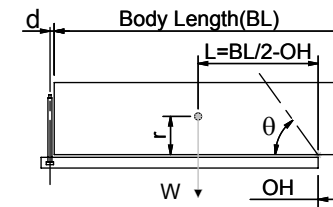

BODY LENGTH (BL)					OH	
5750		6000		6250		
18	48°	17	46°	16	44°	150
20	51°	19	48°	18	46°	450
25	54°	22	51°	21	49°	750

For guidance only;

Higher Rated Pressures may be possible. To check your application, email Edbro plc at <applications@edbro.co.uk>

NOTES

- If hydraulic pressure is used to limit overloading, the system relief valve must be set to the Rated Pressure unless agreed otherwise by Edbro
- The system relief valve can be set to Maximum Pressure if the load is limited by other means. See RATINGS page for advice
- This cylinder is for lifting purposes only and sload conditions must be avoided
- Cylinder is painted in primer paint to RAL5013
- See bracket options page BRKT01, BRKT02
- See installation instructions INSTALL01
- Use oil according to specification OIL01

***Include 14mm Pull Out**

Edbro
SETTING THE INDUSTRY STANDARD

Edbro plc
Nelson Street, Bolton, Lancashire BL3 2JJ UK
Tel +44 (0) 1204 528888 Fax +44 (0) 1204 531957
Email: postmaster@edbro.com Web: www.edbro.com

Technical Specifications are subject to change without notice
Date Created/Updated: 17 February 2011 17:24:41
Refer www.edbro.com to confirm latest specification
All dimensions are in 'mm', unless otherwise stated