

# Cylinder 4 stage front end with outer cover

**\*\*ALLOW 50mm TO REMOVE CAP FOR SERVICING**

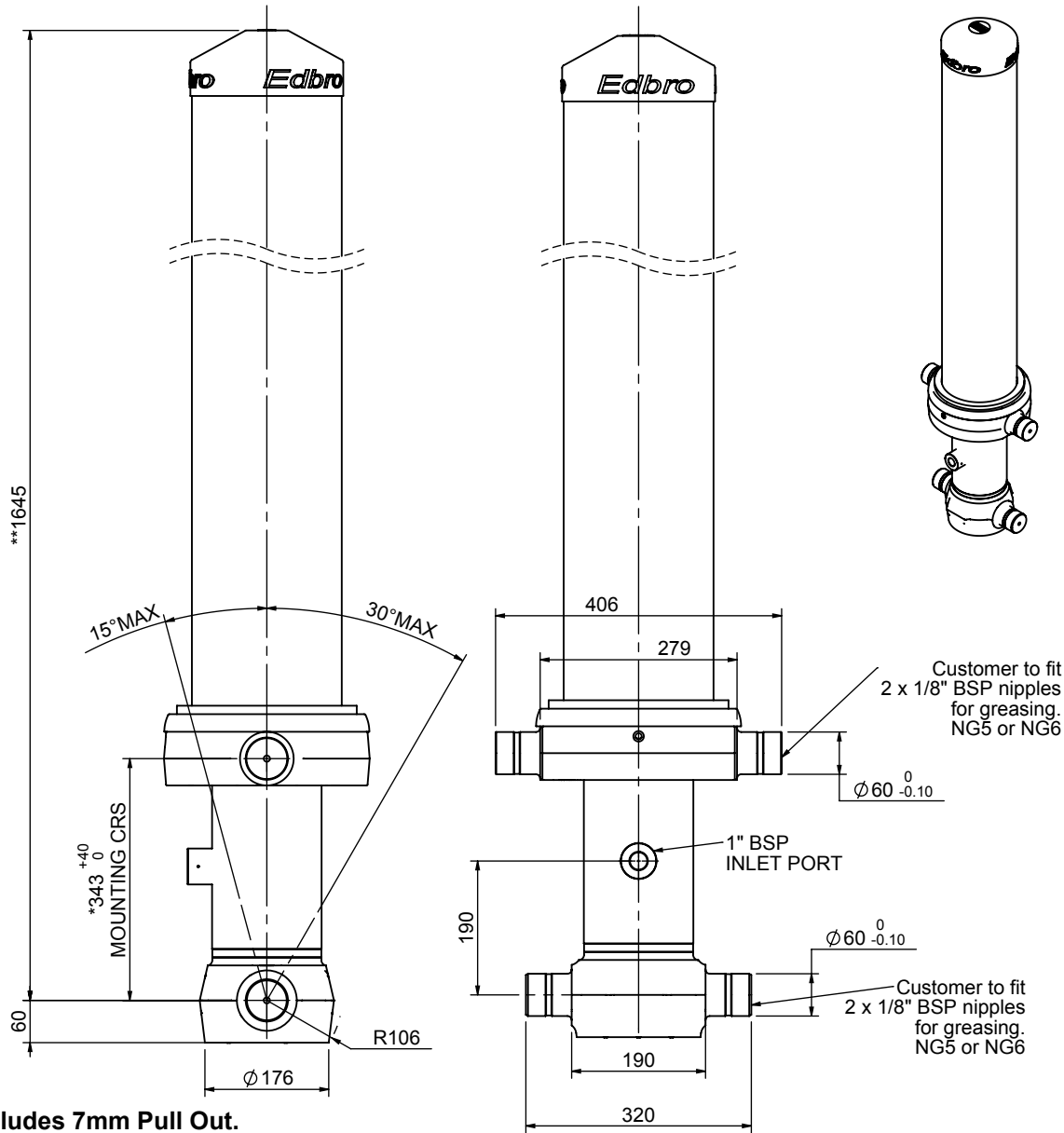

\*Includes 7mm Pull Out.  
All Stages Chrome Plated

# CS130045441B19A31C

SPECIFICATION		TIPPING CAPACITY : 23-33 TONNES***		
Stage	Diameter	Length	Stroke	Swept Volume
-	-	-	-	-
OUTER COVER	Ø213	1260	-	-
0	Ø155	1575	-	-
1	Ø136	1540	1340	19
2	Ø117	1540	1362	15
3	Ø98	1540	1367	10
4	Ø79	1540	1372	7
Total (+5/-10)			5441	51
Final stroke reduced by	0	Priming Volume		14
Cylinder Mass (Kg)	189	Total Volume (Litres)		65
Maximum Pressure (Bar)	190	Max. first stage thrust		170 KN

### \*\*\*TIPPING CAPACITY AT WORKING PRESSURE

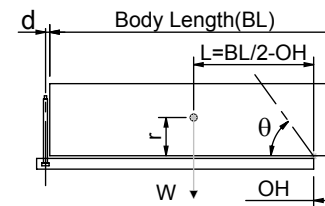

BODY LENGTH (BL)						OH
6750	7250	7750				
26	48°	25	44°	23	41°	150
29	50°	27	46°	25	43°	450
33	53°	30	48°	28	45°	750

$d = 178$ ;  $r = 750$ ; Working Pressure 175 bar  
 Tipping angle ( $\theta$ )  
 Body + payload mass, W (tonne)

**For guidance only;**  
 Higher working pressures and tipping capacities may be possible.  
 To check your application email - [applications@edbro.co.uk](mailto:applications@edbro.co.uk)

### NOTES

1. This cylinder is for lifting purposes only and side load conditions should be avoided
2. Cylinder is painted in primer paint to RAL5013
3. Refer to [www.edbro.com](http://www.edbro.com) for:-
  - Bracket details
  - Installation instructions that must be observed
  - Correct oil selection
  - An explanation of tipping capacity