

Cylinder 4 stage front end with outer cover

****ALLOW 50mm TO REMOVE CAP FOR SERVICING**

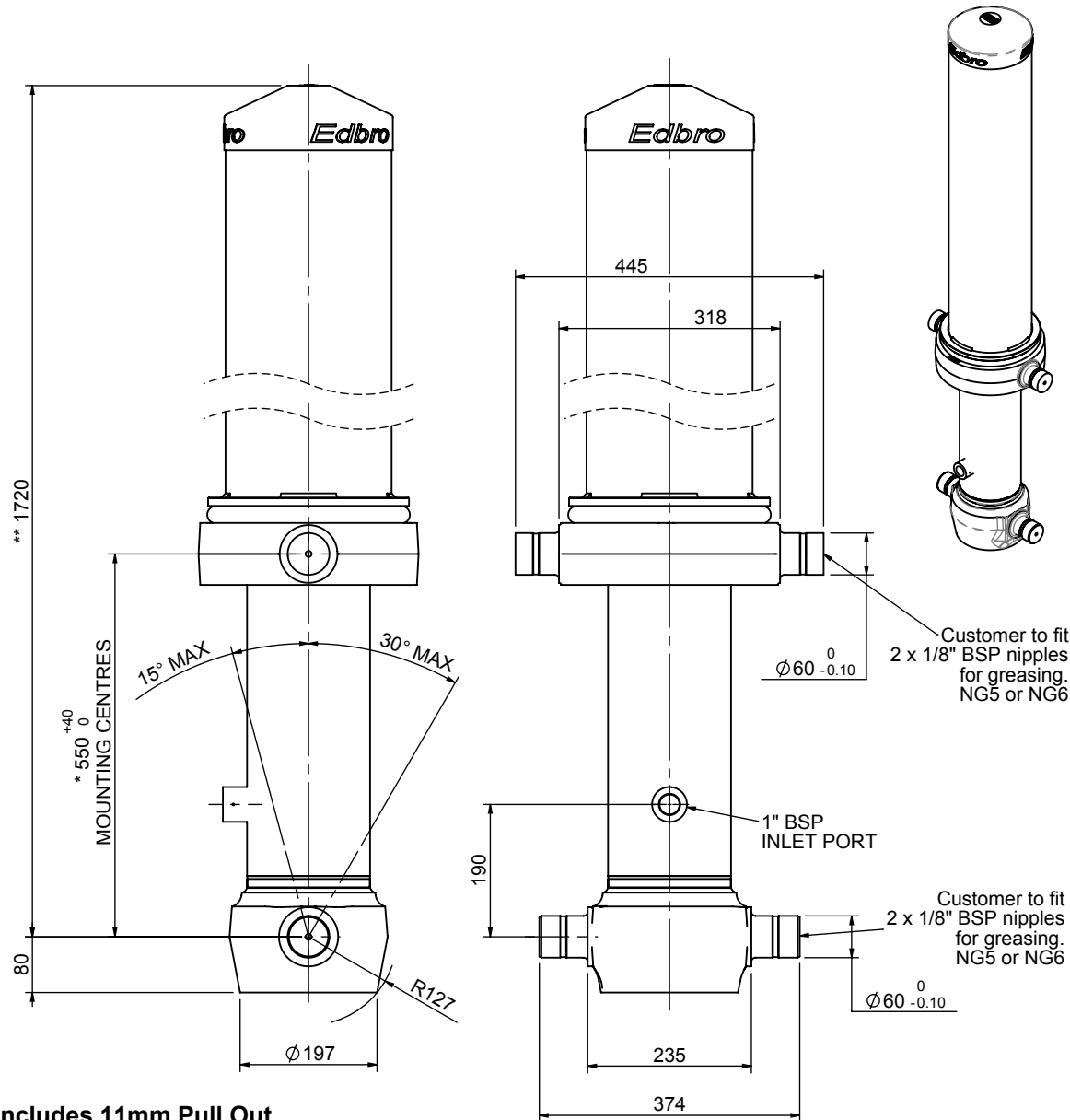

CS150045806B19A12C

SPECIFICATION		TIPPING CAPACITY : 36-51 TONNES***		
Stage	Diameter	Length	Stroke	Swept Volume
-	-	-	-	-
OUTER COVER	239	1135	-	-
0	177	1675	-	-
1	155	1640	1425	27
2	136	1640	1447	21
3	117	1640	1462	16
4	98	1640	1467	11
Total (+5/-10)			5801	75
Final stroke reduced by	0	Priming Volume		19
Cylinder Mass (Kg)	247	Total Volume (Litres)		94
Maximum Pressure (Bar)	190	Max. first stage thrust		225 KN

***TIPPING CAPACITY AT WORKING PRESSURE

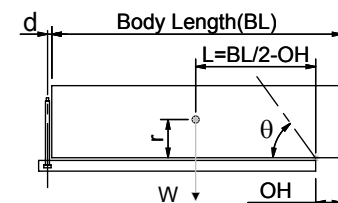

BODY LENGTH (BL)						OH
7000		7500		8000		
40	49°	38	45°	36	42°	150
45	51°	42	47°	39	44°	450
51	54°	46	50°	43	46°	750

$d = 229; r = 750; Working Pressure 175 bar$
 Tipping angle (θ)
 Body + payload mass, W (tonne)
For guidance only;
 Higher working pressures and tipping capacities may be possible.
 To check your application email - applications@edbro.co.uk

NOTES

1. This cylinder is for lifting purposes only and side load conditions should be avoided
2. Cylinder is painted in primer paint to RAL5013
3. Refer to www.edbro.com for;-
 - Bracket details
 - Installation instructions that must be observed
 - Correct oil selection
 - An explanation of tipping capacity

*Includes 11mm Pull Out.

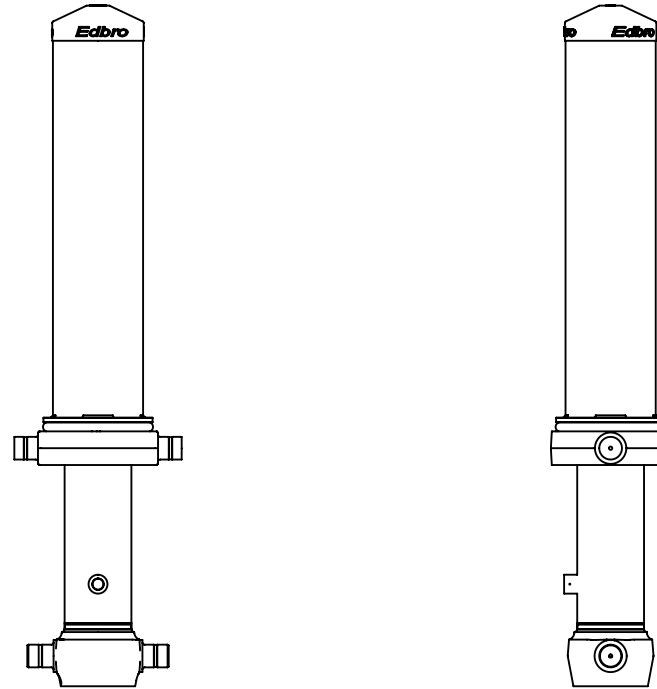

CS150045806B19A12C