

# Cylinder 4 stage front end with spherical eye

## CS150S44656N19M01C

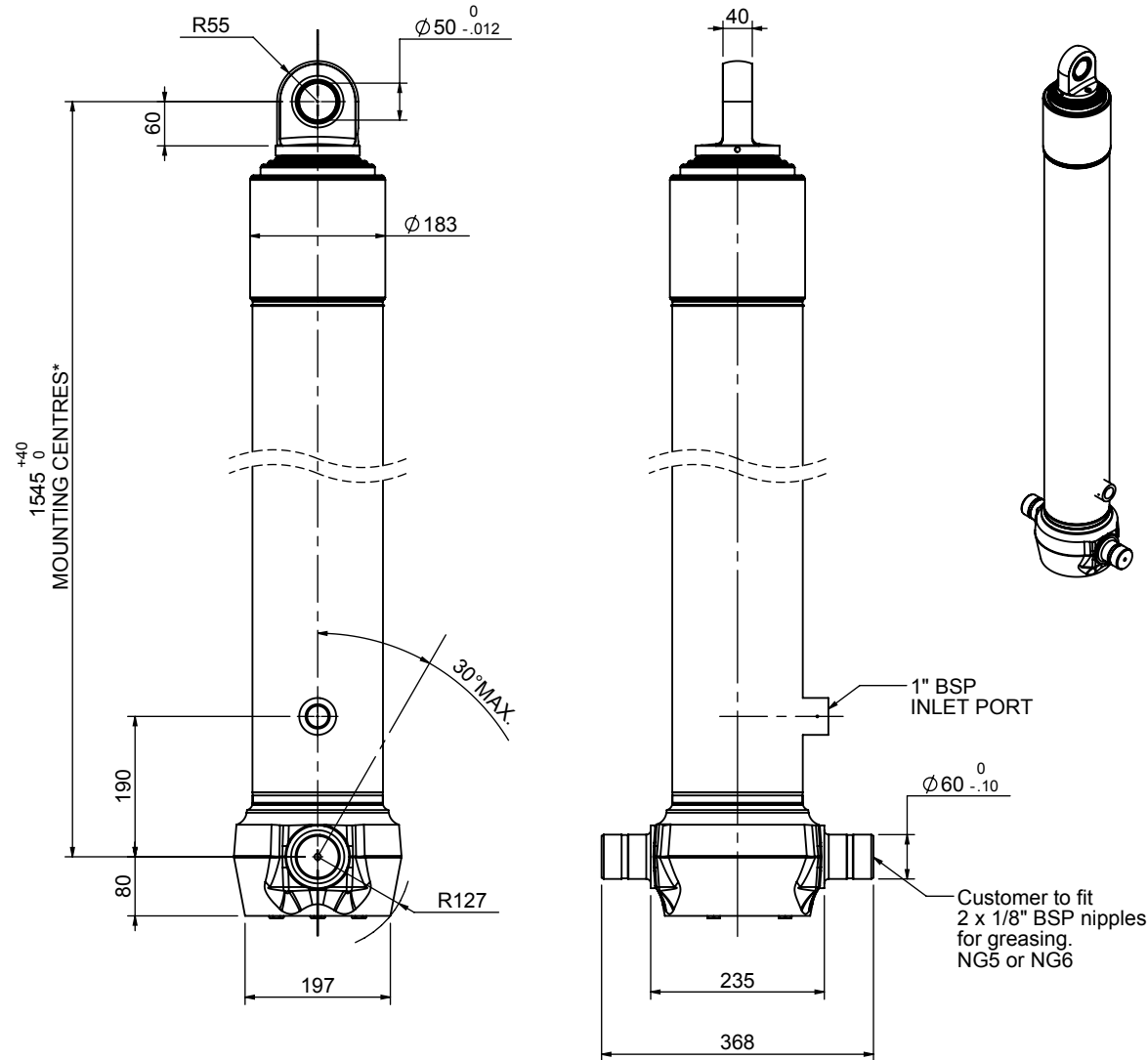

SPECIFICATION		RATED CAPACITY : SEE BELOW		
Stage	Diameter	Length	Stroke	Swept Volume
-	-	-	-	-
-	-	-	-	-
0	177	1525	-	-
1	155	1490	1277	24
2	136	1490	1297	19
3	117	1490	1312	14
4	98	1490	767	6
Final stroke reduced by	550	Total (+5/-10)	4653	63
Cylinder Mass (Kg)	170	Priming Volume		16.9
Rated Pressure (Bar)	170	Total Volume (Litres)		79.9
Maximum Pressure (Bar)	175	Max. first stage thrust		230 KN

### \*\*\*TIPPING CAPACITY AT RATED PRESSURE

$d = 0 ; r = 900$

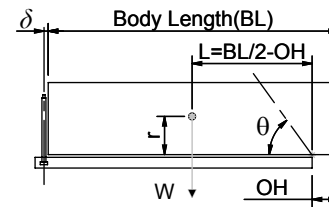

Refer customer to approval drawings

### For guidance only;

Higher Rated Pressures may be possible. To check your application, email Edbro plc at <applications@edbro.co.uk>

### NOTES

- If hydraulic pressure is used to limit overloading, the system relief valve must be set to the Rated Pressure unless agreed otherwise by Edbro
- The system relief valve can be set to Maximum Pressure if the load is limited by other means. See RATINGS page for advice
- This cylinder is for lifting purposes only and sload conditions must be avoided
- Cylinder is painted in primer paint to RAL5013
- See bracket options page BRKT01, BRKT02
- See installation instructions INSTALL01
- Use oil according to specification OIL01

\*Include 9mm Pull Out  
All Stages Chrome Plated

**Edbro**  
SETTING THE INDUSTRY STANDARD

Edbro plc  
Nelson Street, Bolton, Lancashire BL3 2JJ UK  
Tel +44 (0) 1204 528888 Fax +44 (0) 1204 531957  
Email: postmaster@edbro.com Web: www.edbro.com

Technical Specifications are subject to change without notice  
Date Created/Updated: 20 November 2009 08:54:51  
Refer www.edbro.com to confirm latest specification  
All dimensions are in 'mm', unless otherwise stated