

Cylinder 5 stage front end with Outer Cover

NOTE: ALLOW 50mm TO REMOVE CAP FOR SERVICING

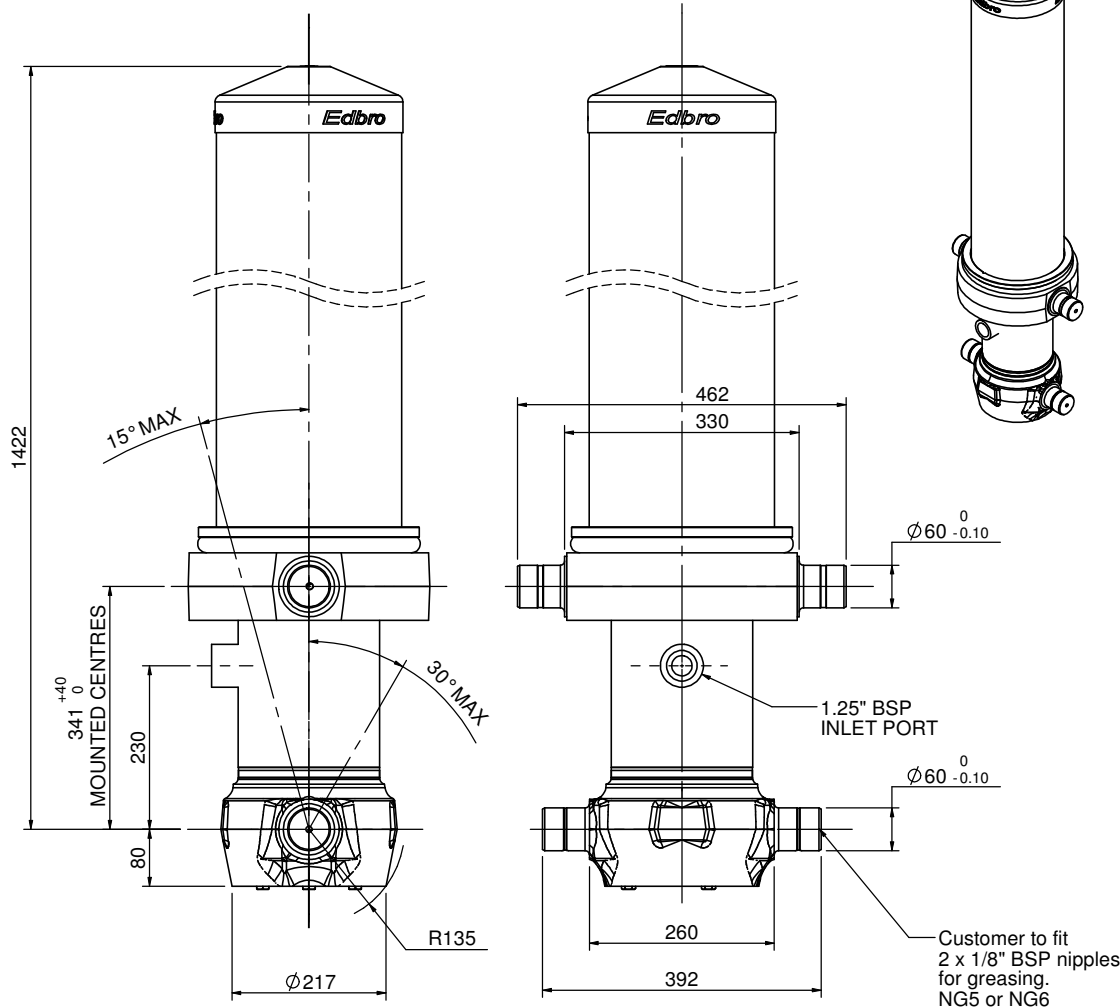

CS170055733B23A11C

SPECIFICATION		RATED CAPACITY : 38-57 TONNES*		
Stage	Diameter	Length	Stroke	Swept Volume
OUTER COVER	260.35	1045		
0	198.12	1375		
1	176.00	1340	1120	27.2
2	154.85	1340	1137	21.4
3	135.75	1340	1147	16.6
4	116.65	1340	1162	12.4
5	97.8	1340	1167	8.8
Final stroke reduced by	0	Total	5733	86.4
Cylinder Mass (Kg)	275	Priming Volume		12.0
Working Pressure (Bar)	175	Total Volume (Litres)		98.4
Maximum Pressure (Bar)	175	Max. first stage thrust		260 KN

*TIPPING CAPACITY AT WORKING PRESSURE

$\delta = 229$; $r = 900$

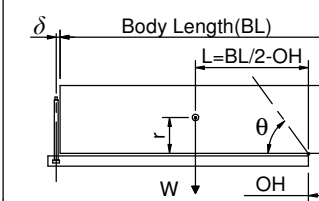

BODY LENGTH (BL)						OH
7000		7500		8000		
44	48°	41	45°	38	42°	150
49	50°	45	47°	42	43°	450
57	53°	51	49°	46	45°	750

For guidance only;

Higher working pressures may be possible. To check your application, email Edbro plc at <applications@edbro.co.uk>

NOTES

- If hydraulic pressure is used to limit overloading, the system relief valve must be set to the Working Pressure unless agreed by Edbro.
- The system relief valve can be set to Maximum Pressure if the load is limited by other means.
- This cylinder is for lifting purposes only and sideload conditions must be avoided.
- Cylinder is painted in primer paint to RAL5010.
- See bracket options page 17BRKT01.
- See installation instructions INSTALL01.
- Use oil according to specification OIL01.

This drawing is available on request in PDF (2D), DXF (2D) or Parasolid (3D) via applications@edbro.co.uk

Edbro
SETTING THE INDUSTRY STANDARD

Edbro plc
Nelson Street, Bolton, Lancashire BL3 2JJ UK
Tel +44 (0) 1204 528888 Fax +44 (0) 1204 531957
Email: postmaster@edbro.com Web: www.edbro.com

Technical Specifications are subject to change without notice
Date Created/Updated: 08 April 2009 17:17:20
Refer www.edbro.com to confirm latest specification
All dimensions are in 'mm', unless otherwise stated