

Cylinder 5 stage front end with Outer Cover

****ALLOW 50mm TO REMOVE CAP FOR SERVICING**

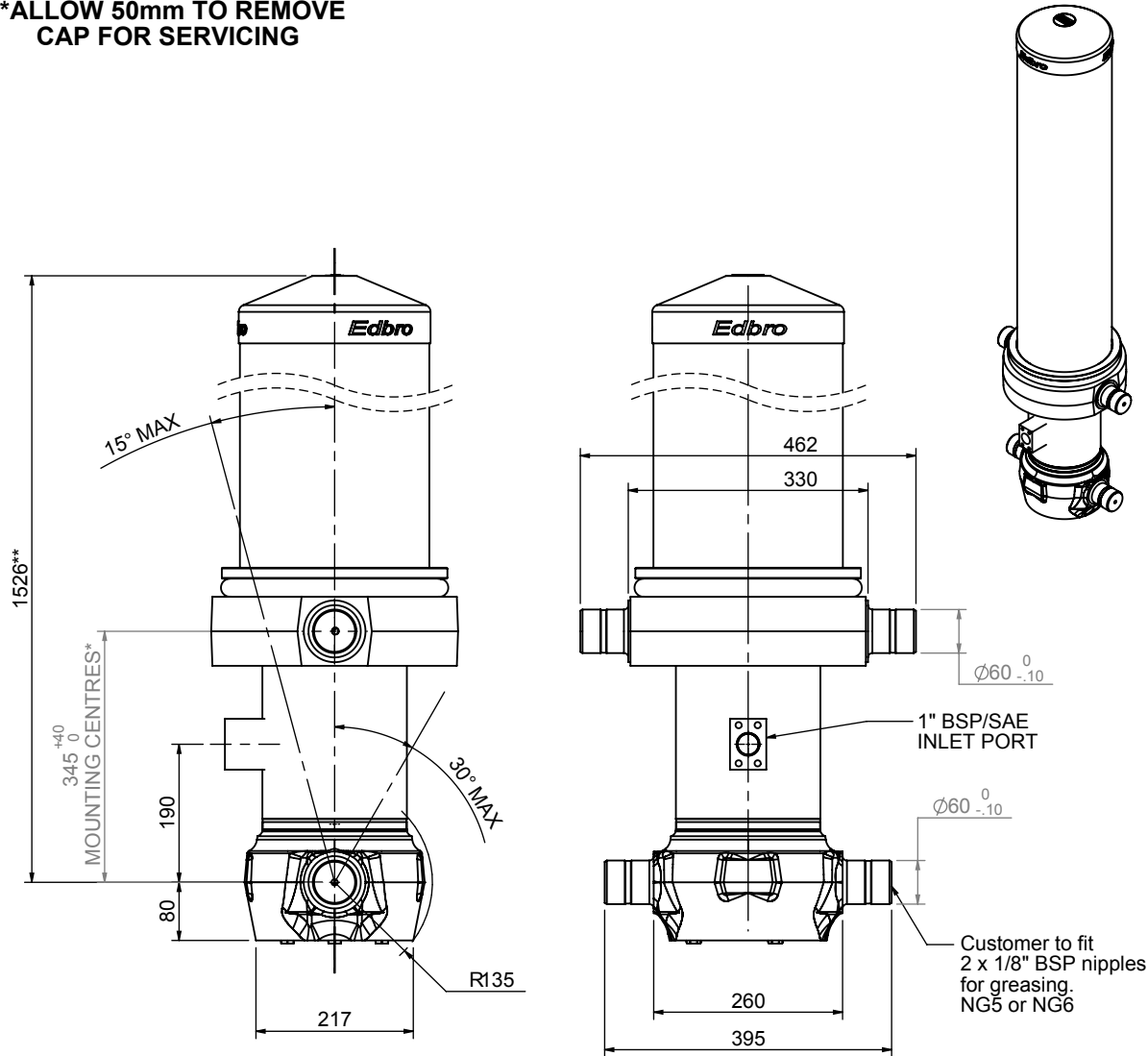

*Includes 12mm Pull Out

CS170056233S19A11

SPECIFICATION		RATED CAPACITY : 38-55 TONNES***		
Stage	Diameter	Length	Stroke	Swept Volume
OUTER COVER	261	1145	-	-
0	199	1475	-	-
1	176	1440	1214	30
2	155	1440	1237	23
3	136	1440	1247	18
4	117	1440	1262	14
5	98	1440	1267	10
Final stroke reduced by	0	Total (+5/-10)	6227	95
Cylinder Mass (Kg)	297.43	Priming Volume	19	
Rated Pressure (Bar)	175	Total Volume (Litres)	114	
Maximum Pressure (Bar)	175	Max. first stage thrust	260 KN	

***TIPPING CAPACITY AT RATED PRESSURE

d = 229 ; r = 900

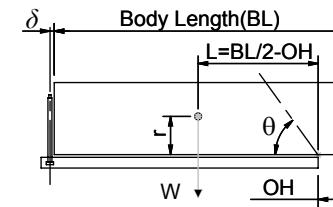

BODY LENGTH (BL)					OH	
7500		8000		8500		
43	49°	40	46°	38	43°	150
48	51°	44	47°	41	44°	450
55	53°	49	50°	45	46°	750

— Tipping angle (θ)
— Body + payload mass, W (tonne)

For guidance only;

Higher Rated Pressures may be possible. To check your application, email Edbro plc at <applications@edbro.co.uk>

NOTES

- If hydraulic pressure is used to limit overloading, the system relief valve must be set to the Rated Pressure unless agreed otherwise by Edbro
- The system relief valve can be set to Maximum Pressure if the load is limited by other means. See RATINGS page for advice
- This cylinder is for lifting purposes only and sload conditions must be avoided
- Cylinder is painted in primer paint to RAL5013
- See bracket options page BRKT01, BRKT02
- See installation instructions INSTALL01
- Use oil according to specification OIL01

Edbro
SETTING THE INDUSTRY STANDARD

Edbro plc
Nelson Street, Bolton, Lancashire BL3 2JJ UK
Tel +44 (0) 1204 528888 Fax +44 (0) 1204 531957
Email: postmaster@edbro.com Web: www.edbro.com

Technical Specifications are subject to change without notice
Date Created/Updated: 02 September 2009 15:05:41
Refer www.edbro.com to confirm latest specification
All dimensions are in 'mm', unless otherwise stated