

Cylinder 5 stage front end with outer cover

NOTE: ALLOW 50mm TO REMOVE CAP FOR SERVICING

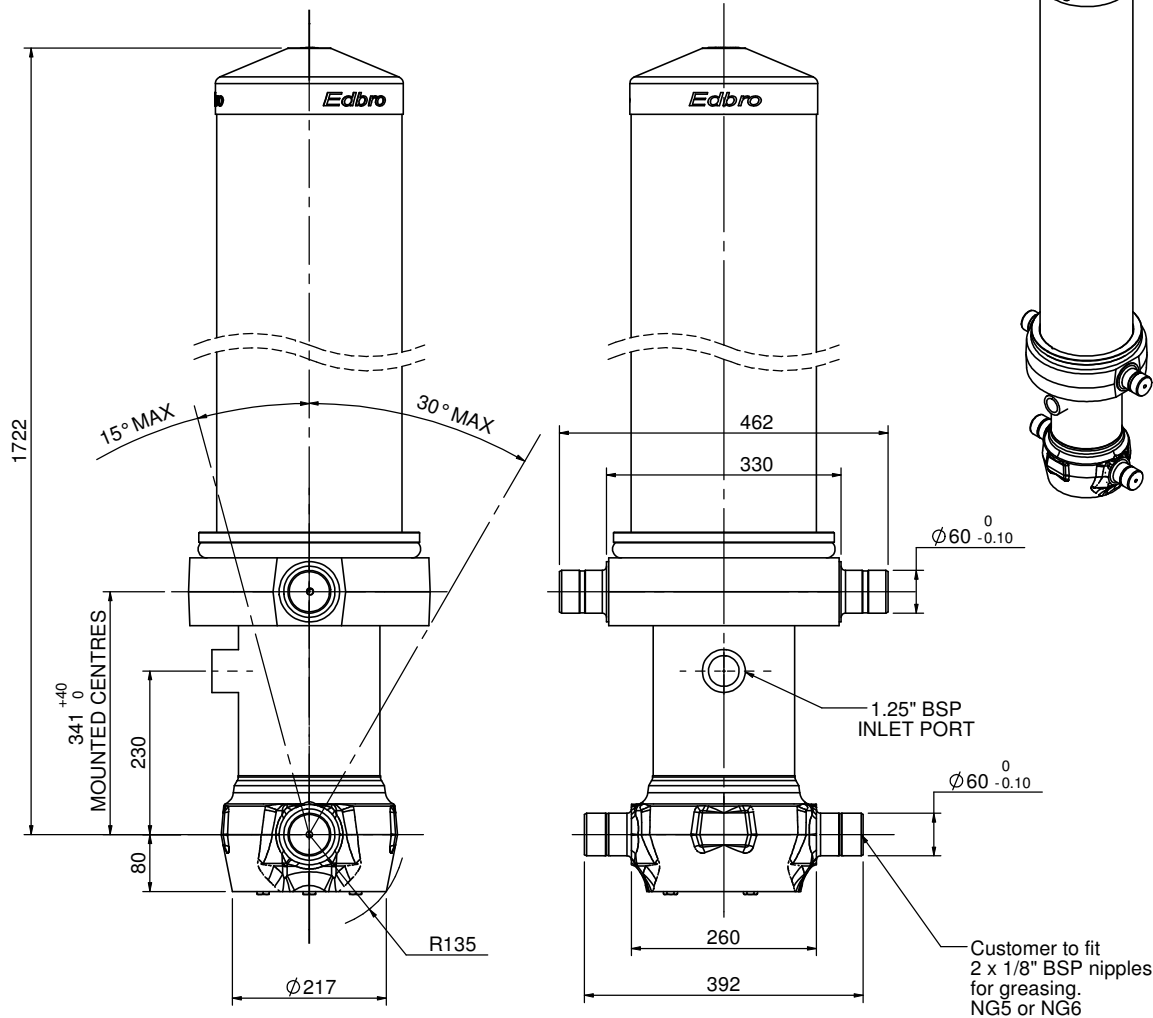

CS170056483B23S11

SPECIFICATION RATED CAPACITY : 40-59 TONNES*

Stage	Diameter	Length	Stroke	Swept Volume
OUTER COVER	260.35	1345		
0	198.12	1675		
1	176.00	1640	1420	34.5
2	154.85	1640	1437	27.1
3	135.75	1640	1447	20.9
4	116.65	1640	1462	15.6
5	97.8	1640	717	5.4
Final stroke reduced by	750	Total	6483	103.5
Cylinder Mass (Kg)	330	Priming Volume		12.0
Working Pressure (Bar)	175	Total Volume (Litres)		115.5
Maximum Pressure (Bar)	175	Max. first stage thrust		260 KN

*TIPPING CAPACITY AT WORKING PRESSURE

$\delta = 229$; $r = 900$

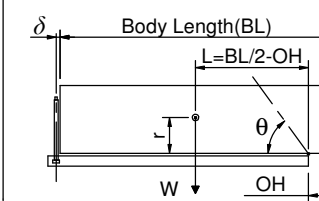

BODY LENGTH (BL)						OH
8000		8500		9000		
46	48°	42	45°	40	42°	150
51	49°	47	46°	43	43°	450
59	52°	52	48°	47	45°	750

For guidance only;

Higher working pressures may be possible. To check your application, email Edbro plc at <applications@edbro.co.uk>

NOTES

- If hydraulic pressure is used to limit overloading, the system relief valve must be set to the Working Pressure unless agreed by Edbro.
- The system relief valve can be set to Maximum Pressure if the load is limited by other means.
- This cylinder is for lifting purposes only and sload conditions must be avoided.
- Cylinder is painted in primer paint to RAL5010.
- See bracket options page 17BRKT01.
- See installation instructions INSTALL01.
- Use oil according to specification OIL01.

This drawing is available on request in PDF (2D), DXF (2D) or Parasolid (3D) via applications@edbro.co.uk

Edbro
SETTING THE INDUSTRY STANDARD

Edbro plc
Nelson Street, Bolton, Lancashire BL3 2JJ UK
Tel +44 (0) 1204 528888 Fax +44 (0) 1204 531957
Email: postmaster@edbro.com Web: www.edbro.com

Technical Specifications are subject to change without notice
Date Created/Updated: 09 April 2009 11:33:04
Refer www.edbro.com to confirm latest specification
All dimensions are in 'mm', unless otherwise stated