

# Cylinder 5 stage front end with Outer Cover

**\*\*ALLOW 50mm TO REMOVE CAP FOR SERVICING**

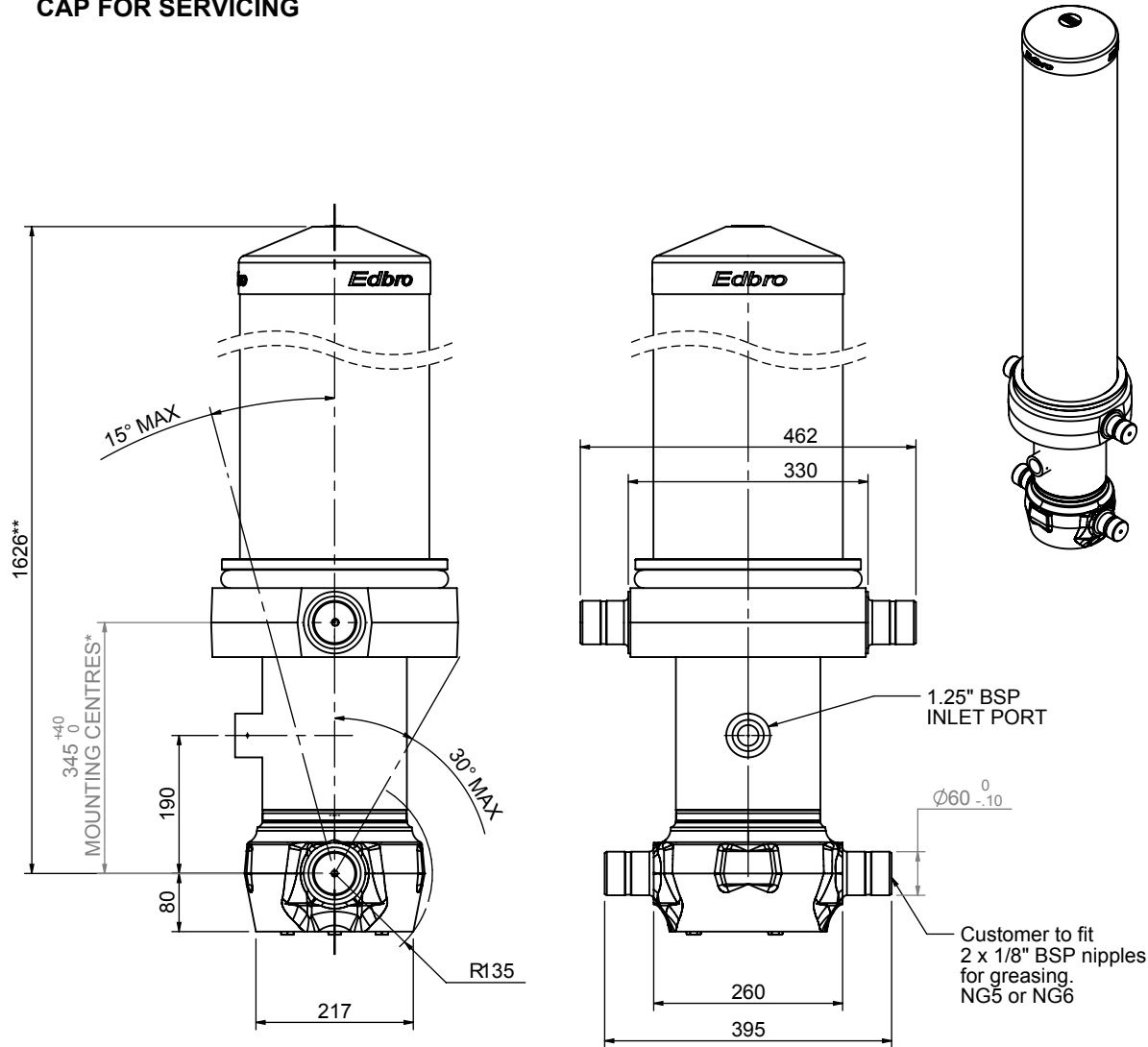

## CS170056733B19A11

SPECIFICATION		RATED CAPACITY : 37-51 TONNES***		
Stage	Diameter	Length	Stroke	Swept Volume
OUTER COVER	261	1245	-	-
0	199	1575	-	-
1	176	1540	1314	32
2	155	1540	1337	25
3	136	1540	1347	20
4	117	1540	1362	15
5	98	1540	1367	10
Final stroke reduced by	0	Total (+5/-10)	6727	102
Cylinder Mass (Kg)	312.23	Priming Volume	21	
Rated Pressure (Bar)	175	Total Volume (Litres)	123	
Maximum Pressure (Bar)	175	Max. first stage thrust	260 KN	

### \*\*\*TIPPING CAPACITY AT RATED PRESSURE

d = 229 ; r = 900

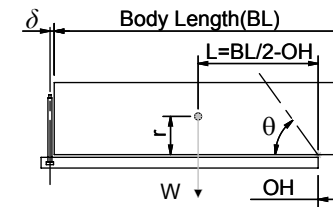

BODY LENGTH (BL)						OH
8250		8750		9250		
41	48°	39	45°	37	42°	150
45	50°	42	47°	40	44°	450
51	52°	46	49°	43	46°	750

— Tipping angle ( $\theta$ )  
— Body + payload mass, W (tonne)

### For guidance only;

Higher Rated Pressures may be possible. To check your application, email Edbro plc at <applications@edbro.co.uk>

### NOTES

- If hydraulic pressure is used to limit overloading, the system relief valve must be set to the Rated Pressure unless agreed otherwise by Edbro
- The system relief valve can be set to Maximum Pressure if the load is limited by other means. See RATINGS page for advice
- This cylinder is for lifting purposes only and sload conditions must be avoided
- Cylinder is painted in primer paint to RAL5013
- See bracket options page BRKT01, BRKT02
- See installation instructions INSTALL01
- Use oil according to specification OIL01

\*Includes 12mm Pull Out

**Edbro**  
SETTING THE INDUSTRY STANDARD

**Edbro plc**  
Nelson Street, Bolton, Lancashire BL3 2JJ UK  
Tel +44 (0) 1204 528888 Fax +44 (0) 1204 531957  
Email: postmaster@edbro.com Web: www.edbro.com

Technical Specifications are subject to change without notice  
Date Created/Updated: 21 August 2009 15:58:29  
Refer www.edbro.com to confirm latest specification  
All dimensions are in 'mm', unless otherwise stated