

Cylinder 5 stage front end with outer cover

****ALLOW 50mm TO REMOVE CAP FOR SERVICING**

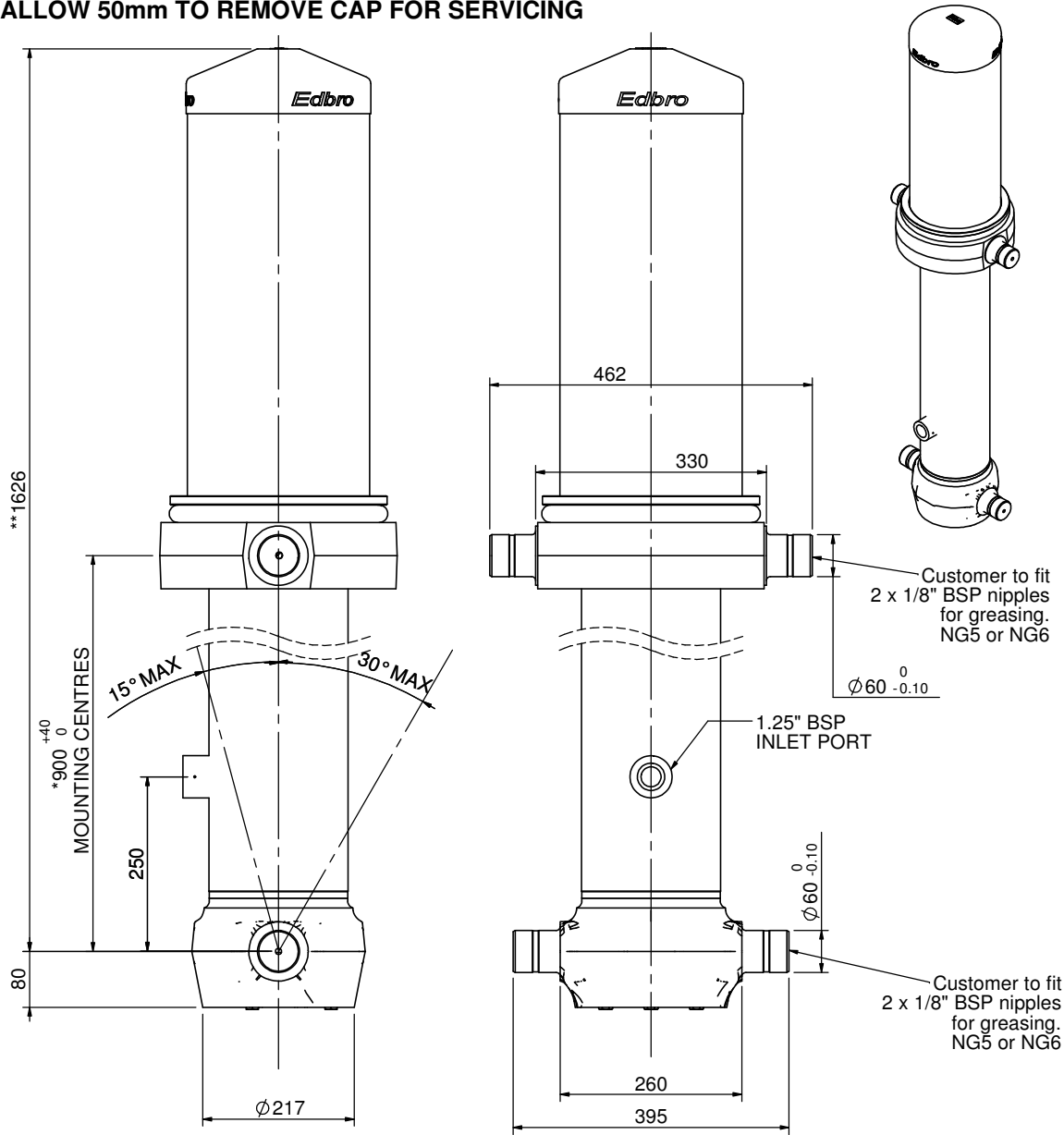

***Includes 12mm Pull Out.**

CS170056733B25A14

SPECIFICATION		TIPPING CAPACITY : 38-50 TONNES***		
Stage	Diameter	Length	Stroke	Swept Volume
OUTER COVER	261	690	-	-
0	199	1575	-	-
1	176	1540	1314	32
2	155	1540	1337	25
3	136	1540	1347	20
4	117	1540	1362	15
5	98	1540	1367	10
Total (+5/-10)			6727	102
Final stroke reduced by	0	Priming Volume		21
Cylinder Mass (Kg)	290	Total Volume (Litres)		123
Maximum Pressure (Bar)	190	Max. first stage thrust		265 KN

***TIPPING CAPACITY AT WORKING PRESSURE

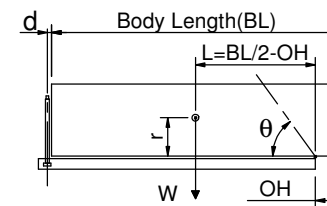

BODY LENGTH (BL)						OH
8000		8500		9000		
40	50°	38	47°	36	44°	150
44	52°	41	49°	39	46°	450
50	54°	45	51°	42	47°	750

$d = 229$; $r = 900$; Working Pressure 165 bar

Tipping angle (θ)

Body + payload mass, W (tonne)

For guidance only;

Higher working pressures and tipping capacities may be possible.

To check your application email - applications@edbro.co.uk

NOTES

1. This cylinder is for lifting purposes only and side load conditions should be avoided
2. Cylinder is painted in primer paint to RAL5013
3. Refer to www.edbro.com for:-
 - Bracket details
 - Installation instructions that must be observed
 - Correct oil selection
 - An explanation of tipping capacity