

Cylinder 4 stage front end with plain eye

CS170E45966B19A01

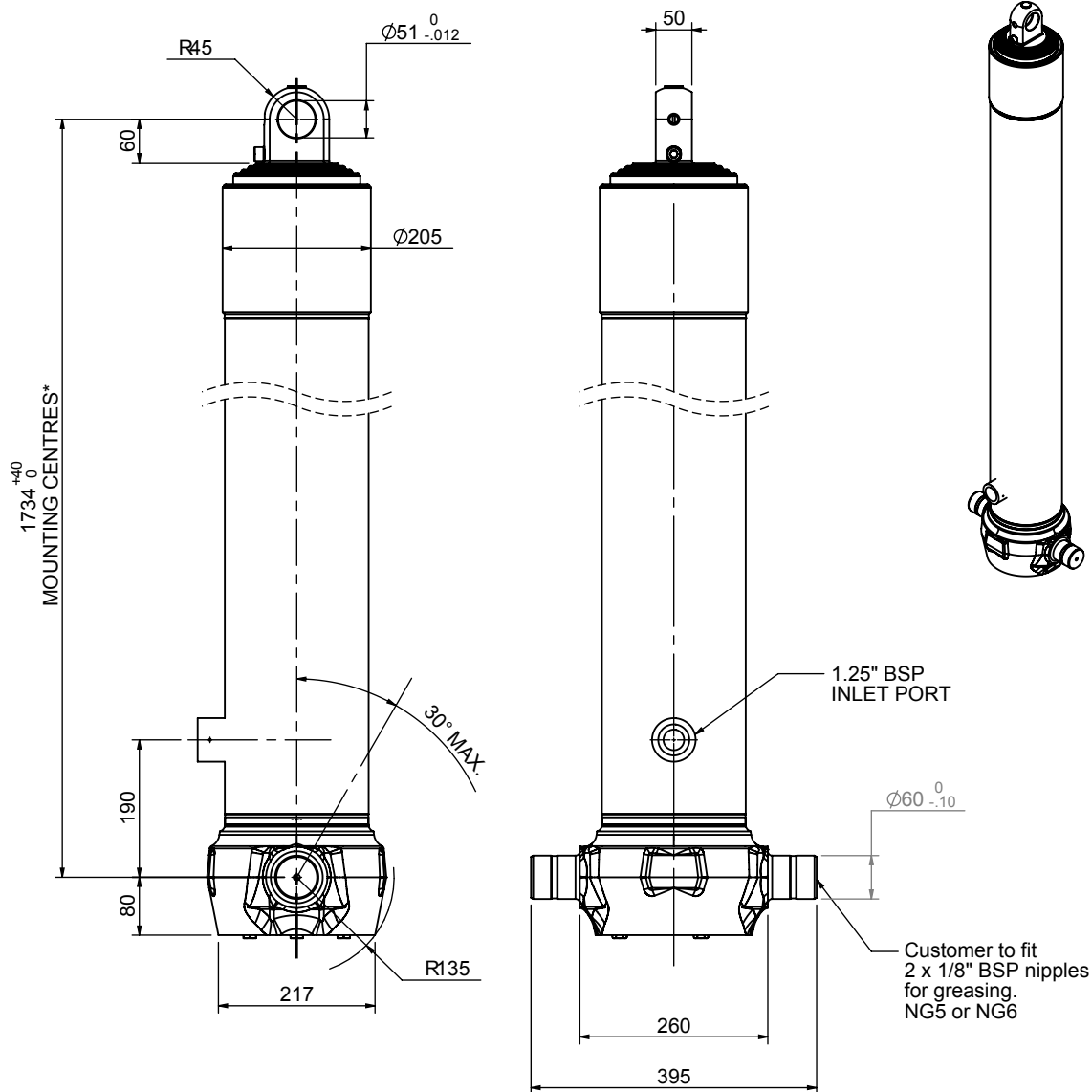

SPECIFICATION		RATED CAPACITY : 39-53 TONNES***		
Stage	Diameter	Length	Stroke	Swept Volume
-	-	-	-	-
-	-	-	-	-
0	199	1725	-	-
1	176	1690	1467	36
2	155	1690	1487	28
3	136	1690	1497	22
4	117	1690	1512	16
Final stroke reduced by	0	Total (+5/-10)	5963	102
Cylinder Mass (Kg)	235.22	Priming Volume	25	
Rated Pressure (Bar)	135	Total Volume (Litres)	127	
Maximum Pressure (Bar)	175	Max. first stage thrust	260 KN	

***TIPPING CAPACITY AT RATED PRESSURE

d = 0 ; r = 900

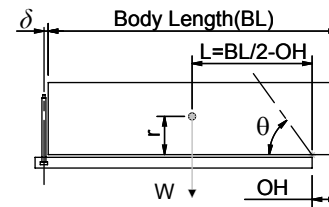

BODY LENGTH (BL)					OH	
7500		8000		8500		
43	49°	40	46°	39	43°	150
47	51°	44	47°	41	44°	450
53	54°	48	50°	45	46°	750

Tipping angle (θ)
 Body + payload mass, W (tonne)

For guidance only;

Higher Rated Pressures may be possible. To check your application, email Edbro plc at <applications@edbro.co.uk>

NOTES

- If hydraulic pressure is used to limit overloading, the system relief valve must be set to the Rated Pressure unless agreed otherwise by Edbro
- The system relief valve can be set to Maximum Pressure if the load is limited by other means. See RATINGS page for advice
- This cylinder is for lifting purposes only and sload conditions must be avoided
- Cylinder is painted in primer paint to RAL5013
- See bracket options page BRKT01, BRKT02
- See installation instructions INSTALL01
- Use oil according to specification OIL01

*Includes 9mm Pull Out Last Stage Chrome Plated



Edbro plc
 Nelson Street, Bolton, Lancashire BL3 2JJ UK
 Tel +44 (0) 1204 528888 Fax +44 (0) 1204 531957
 Email: postmaster@edbro.com Web: www.edbro.com

Technical Specifications are subject to change without notice
 Date Created/Updated: 01 September 2009 09:50:18
 Refer www.edbro.com to confirm latest specification
 All dimensions are in 'mm', unless otherwise stated