

Cylinder 5 stage front end with plain eye

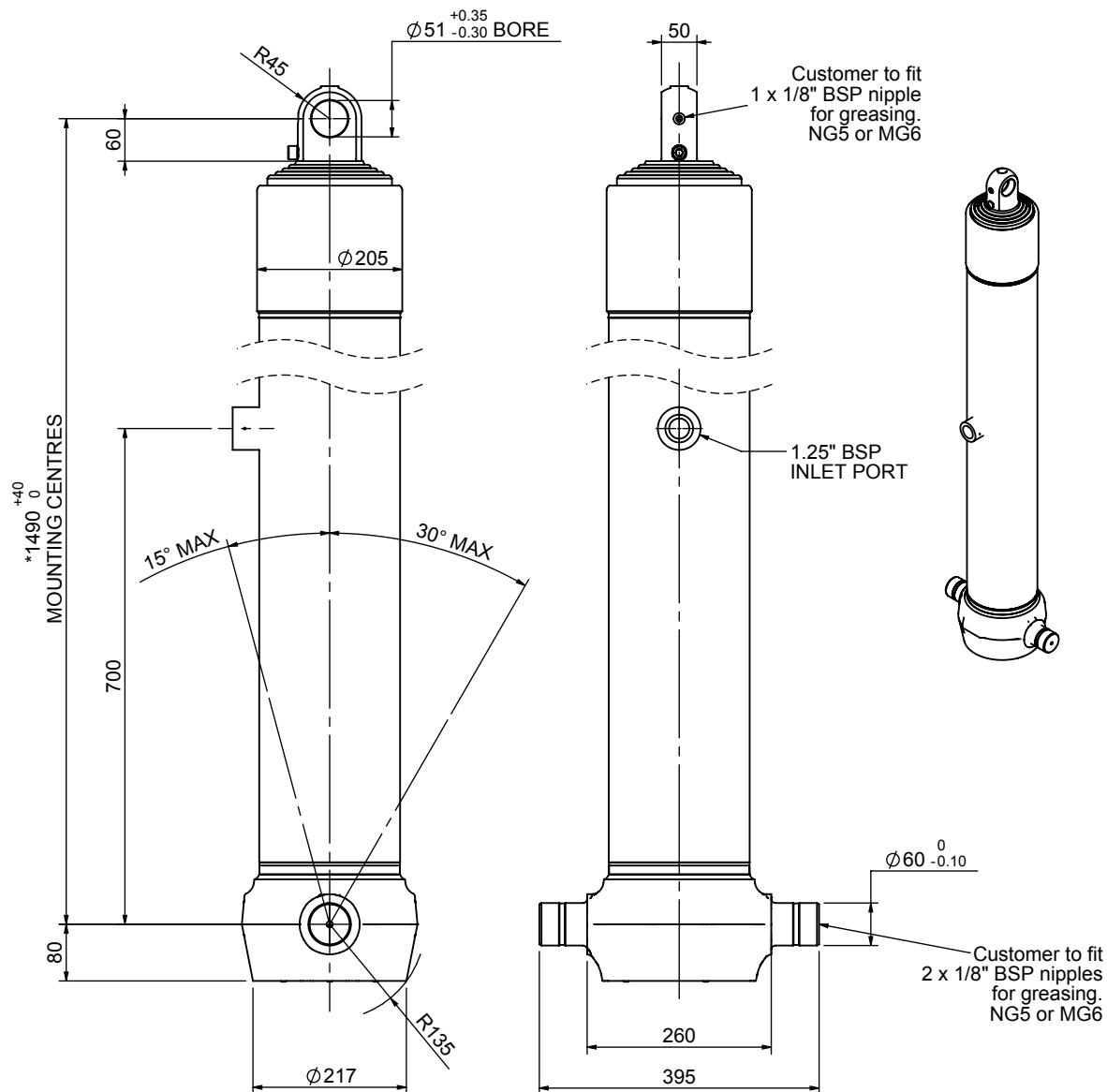

*Includes 9mm Pull Out.
Last Stage Chrome Plated

CS170E56233B70A01

SPECIFICATION		TIPPING CAPACITY : 28-40 TONNES***		
Stage	Diameter	Length	Stroke	Swept Volume
-	-	-	-	-
0	199	1475	-	-
1	176	1440	1217	30
2	155	1440	1237	23
3	136	1440	1247	18
4	117	1440	1262	14
5	98	1440	1267	10
Total (+5/-10)			6230	95
Final stroke reduced by	0	Priming Volume		19
Cylinder Mass (Kg)	219	Total Volume (Litres)		114
Maximum Pressure (Bar)	190	Max. first stage thrust		265 KN

***TIPPING CAPACITY AT WORKING PRESSURE

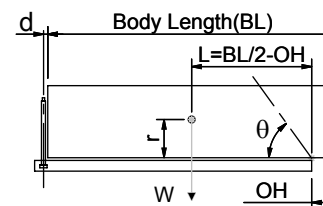

BODY LENGTH (BL)						OH
7750		8250		8750		
32	49°	30	46°	28	43°	150
35	52°	32	48°	30	45°	450
40	54°	36	50°	33	47°	750

d = 0; r = 900; Working Pressure 135 bar

For guidance only;

Higher working pressures and tipping capacities may be possible.

To check your application email - applications@edbro.co.uk

NOTES

1. This cylinder is for lifting purposes only and side load conditions should be avoided
2. Cylinder is painted in primer paint to RAL5013
3. Refer to www.edbro.com for:-
 - Bracket details
 - Installation instructions that must be observed
 - Correct oil selection
 - An explanation of tipping capacity

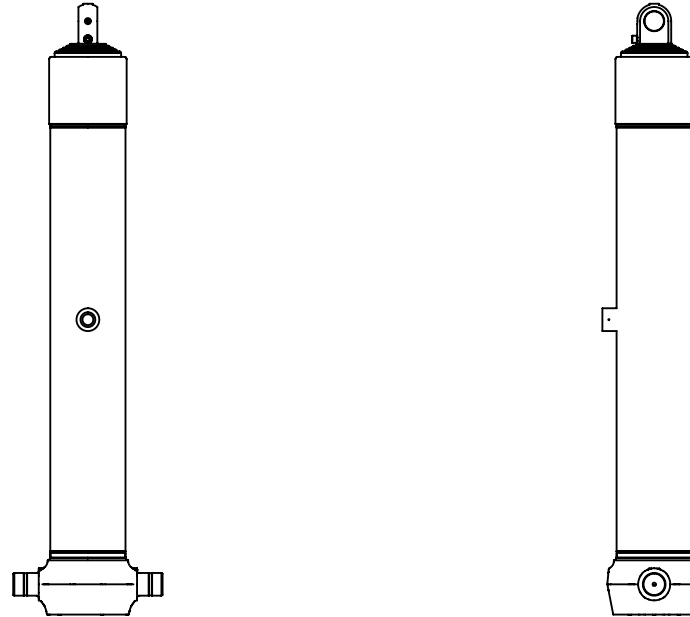

CS170E56233B70A01