

# Cylinder 5 stage front end with plain eye

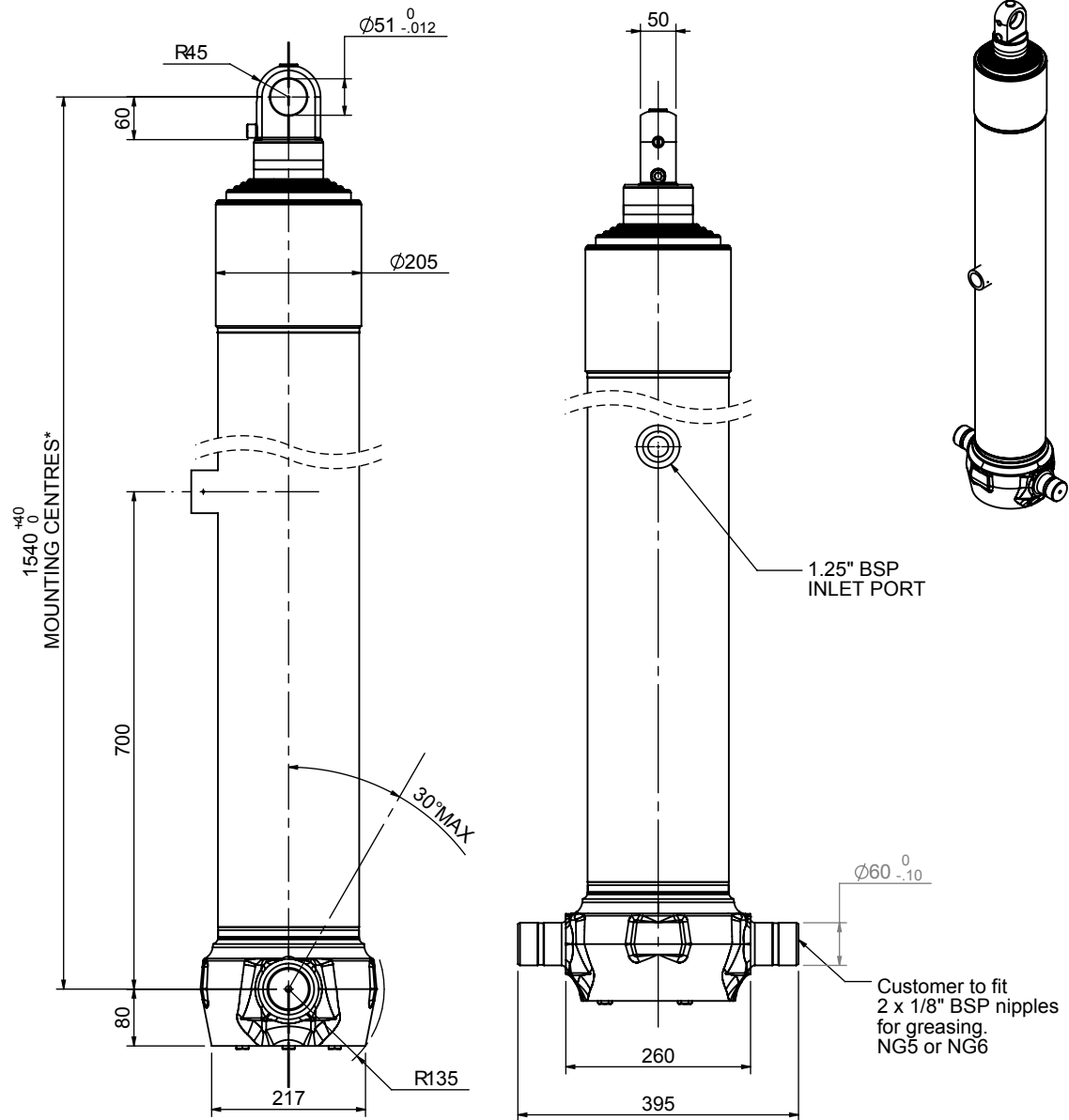

# CS170E56233B70A03

SPECIFICATION		RATED CAPACITY : 30-40 TONNES***		
Stage	Diameter	Length	Stroke	Swept Volume
-	-	-	-	-
0	199	1475	-	-
1	176	1440	1217	30
2	155	1440	1237	23
3	136	1440	1247	18
4	117	1440	1262	14
5	98	1490	1267	10
Final stroke reduced by	0	Total (+5/-10)	6230	95
Cylinder Mass (Kg)	222.65	Priming Volume	19	
Rated Pressure (Bar)	135	Total Volume (Litres)	114	
Maximum Pressure (Bar)	175	Max. first stage thrust	260 KN	

### \*\*\*TIPPING CAPACITY AT RATED PRESSURE

d = 0 ; r = 900

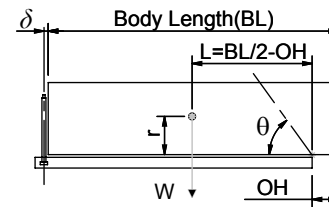

BODY LENGTH (BL)						OH
7750		8250		8750		
31	49°	30	46°			150
35	52°	32	48°	30	45°	450
40	54°	36	50°	33	47°	750

### For guidance only;

Higher Rated Pressures may be possible. To check your application, email Edbro plc at <applications@edbro.co.uk>

### NOTES

- If hydraulic pressure is used to limit overloading, the system relief valve must be set to the Rated Pressure unless agreed otherwise by Edbro
- The system relief valve can be set to Maximum Pressure if the load is limited by other means. See RATINGS page for advice
- This cylinder is for lifting purposes only and sload conditions must be avoided
- Cylinder is painted in primer paint to RAL5013
- See bracket options page BRKT01, BRKT02
- See installation instructions INSTALL01
- Use oil according to specification OIL01

\*Includes 9mm Pull Out Last Stage Chrome Plated



**Edbro plc**  
 Nelson Street, Bolton, Lancashire BL3 2JJ UK  
 Tel +44 (0) 1204 528888 Fax +44 (0) 1204 531957  
 Email: postmaster@edbro.com Web: www.edbro.com

Technical Specifications are subject to change without notice  
 Date Created/Updated: 26 August 2009 07:50:31  
 Refer www.edbro.com to confirm latest specification  
 All dimensions are in 'mm', unless otherwise stated