

Cylinder 5 stage front end with plain eye

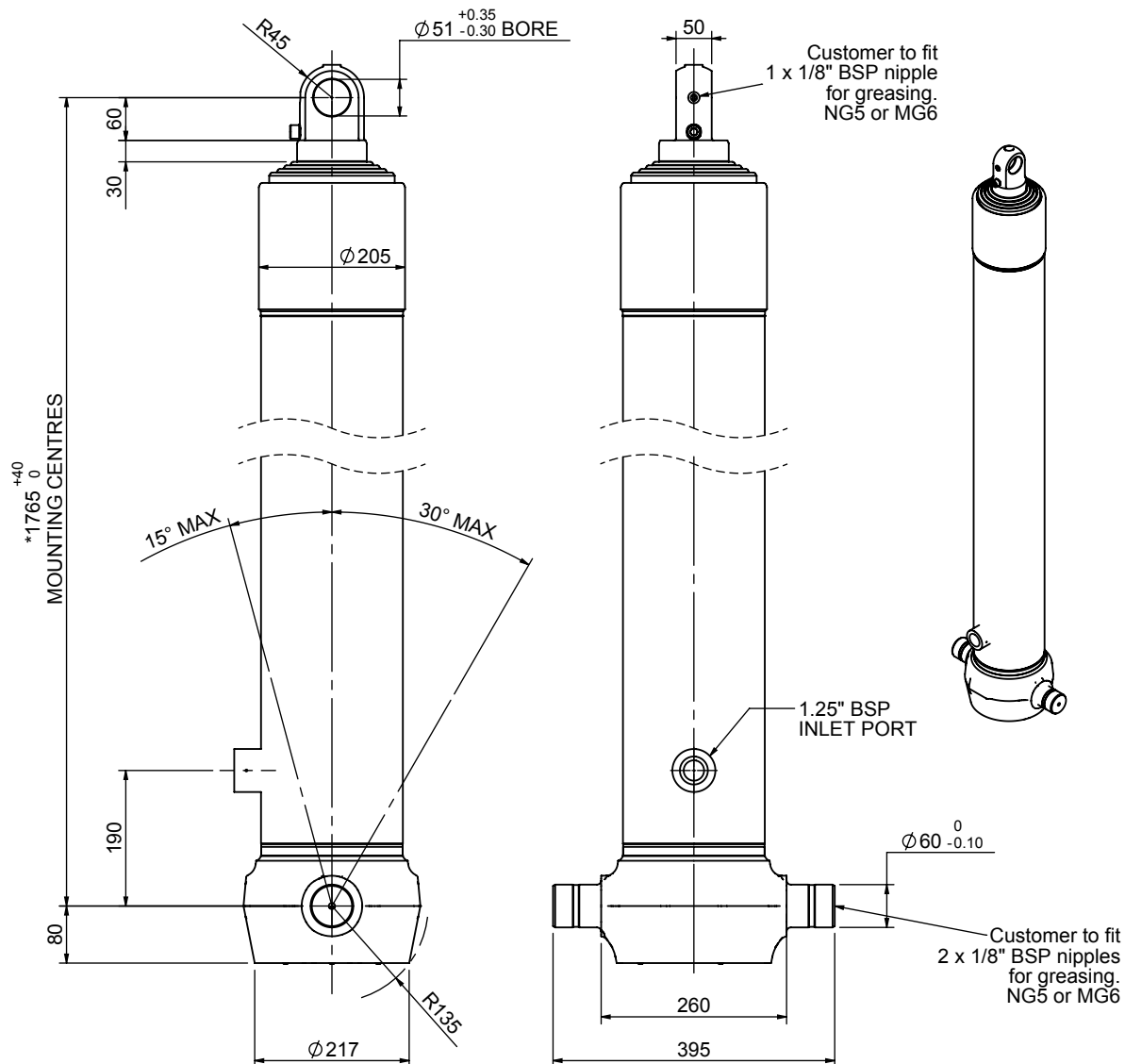

*Includes 9mm Pull Out.
All Stages Chrome Plated

CS170E57033B19K02C

SPECIFICATION		TIPPING CAPACITY : 27-35 TONNES***		
Stage	Diameter	Length	Stroke	Swept Volume
-	-	-	-	-
0	199	1725	-	-
1	176	1690	1467	36
2	155	1690	1487	28
3	136	1690	1497	22
4	117	1690	1512	16
5	98	1715	1067	8
Total (+5/-10)			7030	110
Final stroke reduced by	450	Priming Volume		23
Cylinder Mass (Kg)	251	Total Volume (Litres)		133
Maximum Pressure (Bar)	190	Max. first stage thrust		265 KN

***TIPPING CAPACITY AT WORKING PRESSURE

		BODY LENGTH (BL)			OH
		8750	9250	9750	
28	49°	27	46°	150	
31	51°	29	48°	450	
35	53°	32	50°	750	

d = 0; r = 900; Working Pressure 120 bar
 For guidance only;
 Higher working pressures and tipping capacities may be possible.
 To check your application email - applications@edbro.co.uk

- NOTES**
1. This cylinder is for lifting purposes only and side load conditions should be avoided
 2. Cylinder is painted in primer paint to RAL5013
 3. Refer to www.edbro.com for:-
 - Bracket details
 - Installation instructions that must be observed
 - Correct oil selection
 - An explanation of tipping capacity

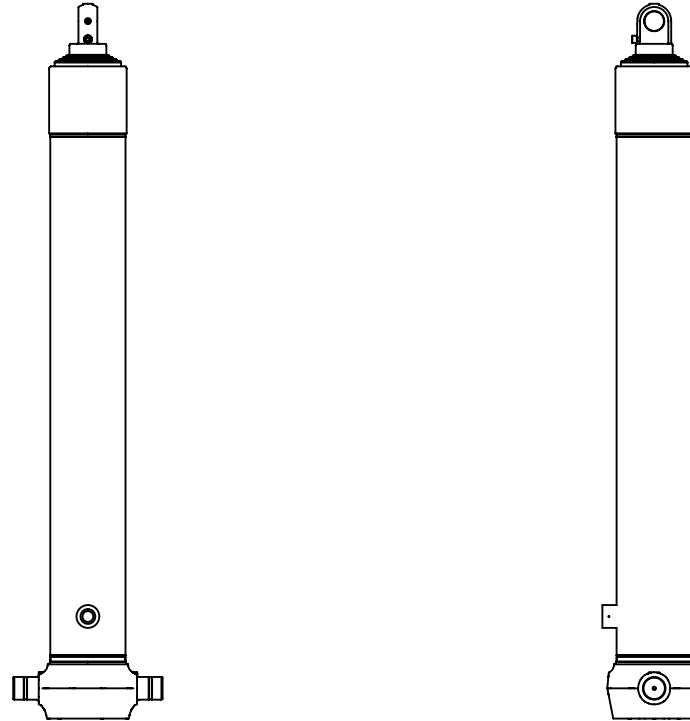

CS170E57033B19K02C