

Cylinder 5 stage front end with spherical eye

CS170S55233B70L08

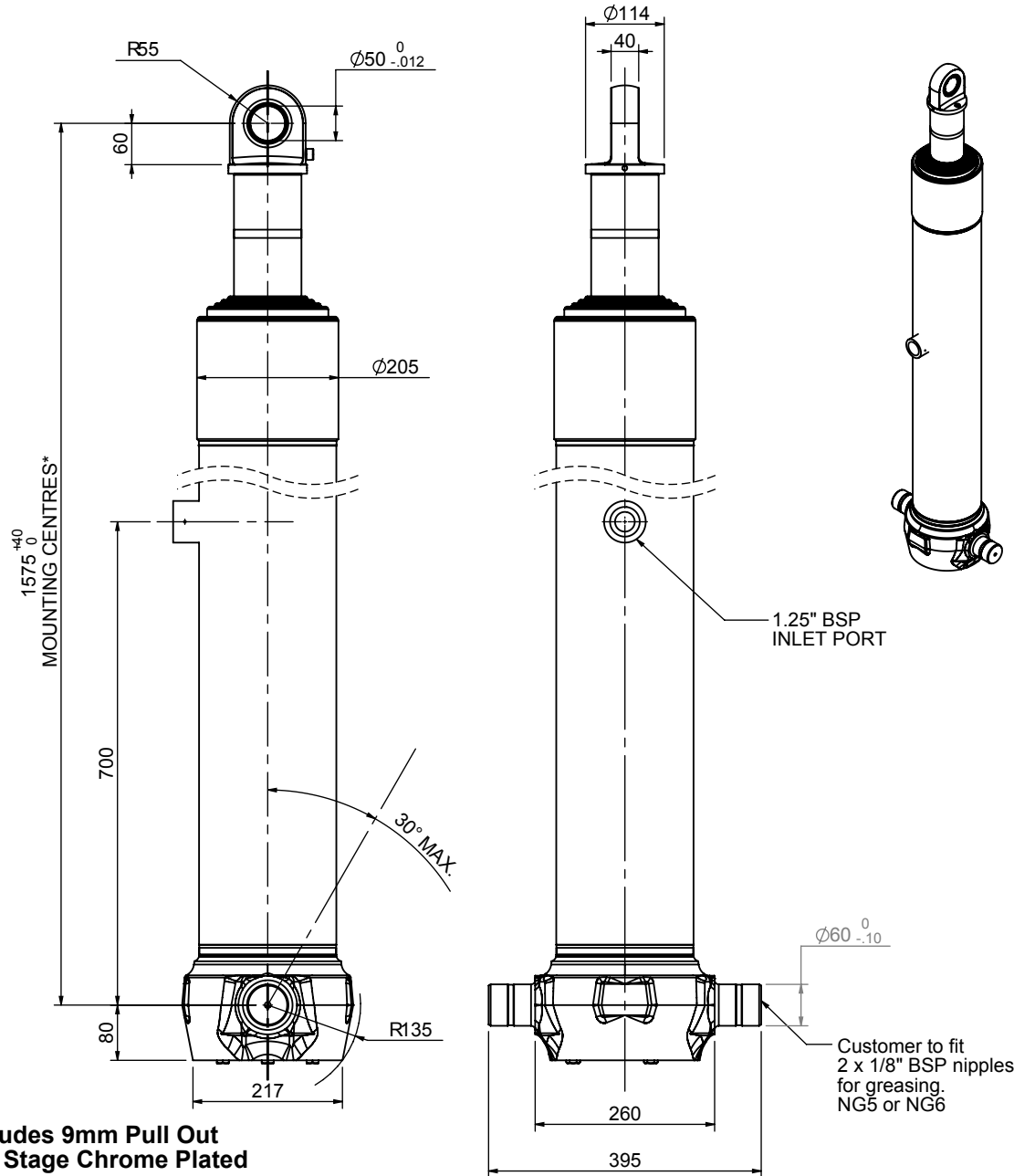

*Includes 9mm Pull Out Last Stage Chrome Plated

SPECIFICATION		RATED CAPACITY : 37-57 TONNES***		
Stage	Diameter	Length	Stroke	Swept Volume
-	-	-	-	-
0	199	1375	-	-
1	176	1340	1117	27
2	155	1340	1137	21
3	136	1340	1147	17
4	117	1340	1162	12
5	98	1515	667	5
Final stroke reduced by	500	Total (+5/-10)	5230	82
Cylinder Mass (Kg)	215.87	Priming Volume	18	
Rated Pressure (Bar)	175	Total Volume (Litres)	100	
Maximum Pressure (Bar)	175	Max. first stage thrust	260 KN	

***TIPPING CAPACITY AT RATED PRESSURE

$d = 0 ; r = 900$

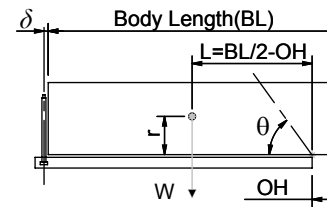

BODY LENGTH (BL)					OH	
6750		7250		7750		
43	46°	40	42°	37	39°	150
49	48°	44	44°	41	41°	450
57	51°	50	47°	45	43°	750

Tipping angle (θ)
 Body + payload mass, W (tonne)

For guidance only;

Higher Rated Pressures may be possible. To check your application, email Edbro plc at <applications@edbro.co.uk>

NOTES

- If hydraulic pressure is used to limit overloading, the system relief valve must be set to the Rated Pressure unless agreed otherwise by Edbro
- The system relief valve can be set to Maximum Pressure if the load is limited by other means. See RATINGS page for advice
- This cylinder is for lifting purposes only and sload conditions must be avoided
- Cylinder is painted in primer paint to RAL5013
- See bracket options page BRKT01, BRKT02
- See installation instructions INSTALL01
- Use oil according to specification OIL01