

Cylinder 5 stage front end with spherical eye

CS170S55483B70A01C

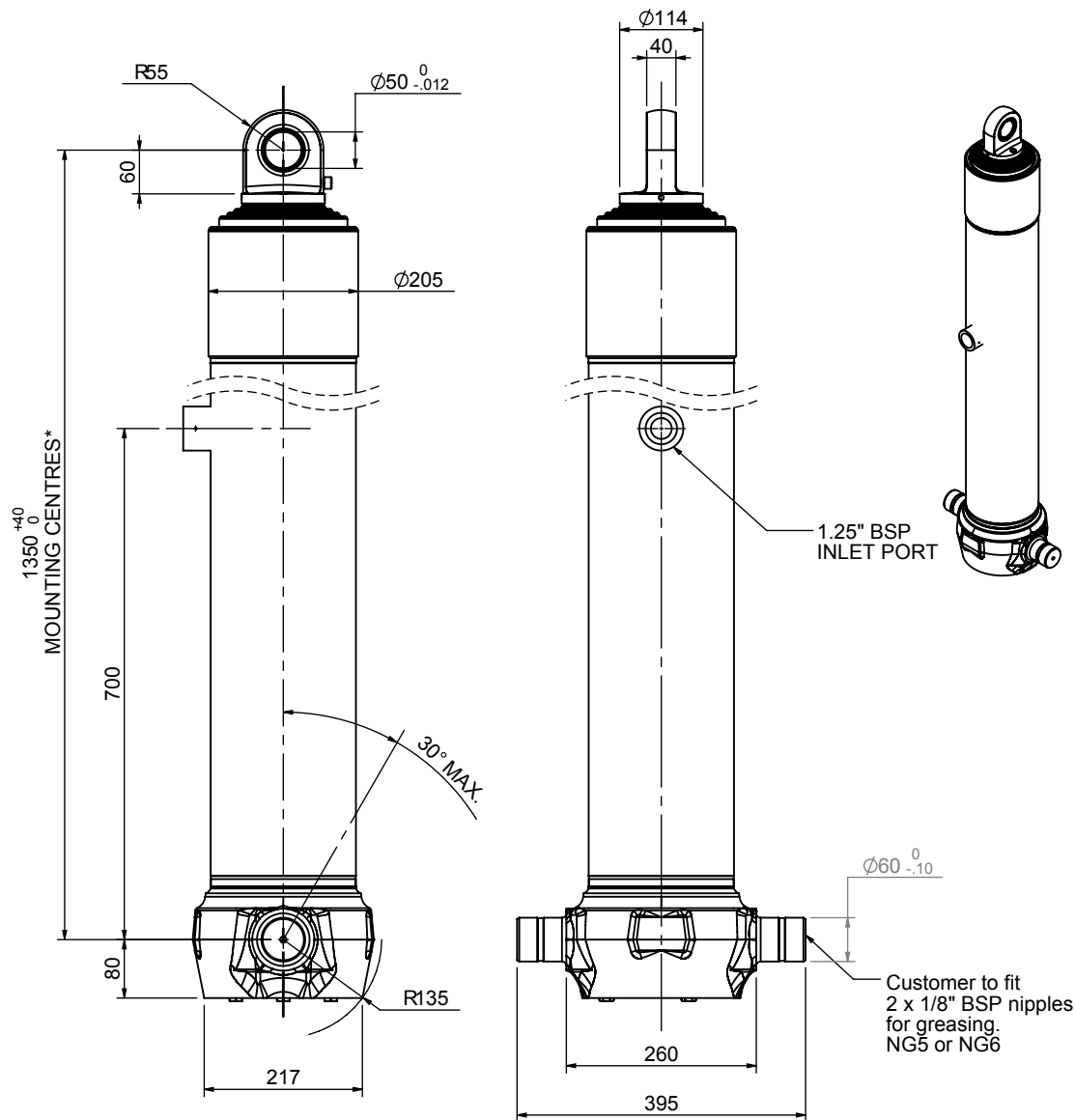

SPECIFICATION RATED CAPACITY : 37-54 TONNES***

Stage	Diameter	Length	Stroke	Swept Volume
-	-	-	-	-
0	199	1325	-	-
1	176	1290	1067	26
2	155	1290	1087	21
3	136	1290	1097	16
4	117	1290	1112	12
5	98	1290	1117	8
Final stroke reduced by	0	Total (+5/-10)	5480	83
Cylinder Mass (Kg)	207.69	Priming Volume	17	
Rated Pressure (Bar)	175	Total Volume (Litres)	100	
Maximum Pressure (Bar)	175	Max. first stage thrust	260 KN	

***TIPPING CAPACITY AT RATED PRESSURE

$d = 0 ; r = 900$

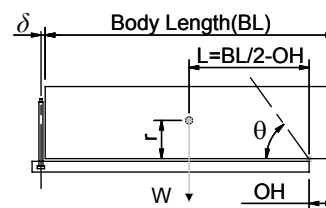

BODY LENGTH (BL)						OH
7000		7500		8000		
41	48°	39	44°	37	41°	150
47	50°	42	47°	40	43°	450
54	53°	48	49°	44	45°	750

Tipping angle (θ)
Body + payload mass, W (tonne)

For guidance only;

Higher Rated Pressures may be possible. To check your application, email Edbro plc at <applications@edbro.co.uk>

NOTES

- If hydraulic pressure is used to limit overloading, the system relief valve must be set to the Rated Pressure unless agreed otherwise by Edbro
- The system relief valve can be set to Maximum Pressure if the load is limited by other means. See RATINGS page for advice
- This cylinder is for lifting purposes only and sload conditions must be avoided
- Cylinder is painted in primer paint to RAL5013
- See bracket options page BRKT01, BRKT02
- See installation instructions INSTALL01
- Use oil according to specification OIL01

*Includes 9mm Pull Out
All Stages Chrome Plated

Edbro
SETTING THE INDUSTRY STANDARD

Edbro plc
Nelson Street, Bolton, Lancashire BL3 2JJ UK
Tel +44 (0) 1204 528888 Fax +44 (0) 1204 531957
Email: postmaster@edbro.com Web: www.edbro.com

Technical Specifications are subject to change without notice
Date Created/Updated: 13 August 2009 14:32:34
Refer www.edbro.com to confirm latest specification
All dimensions are in 'mm', unless otherwise stated