

Cylinder 5 stage front end with spherical eye

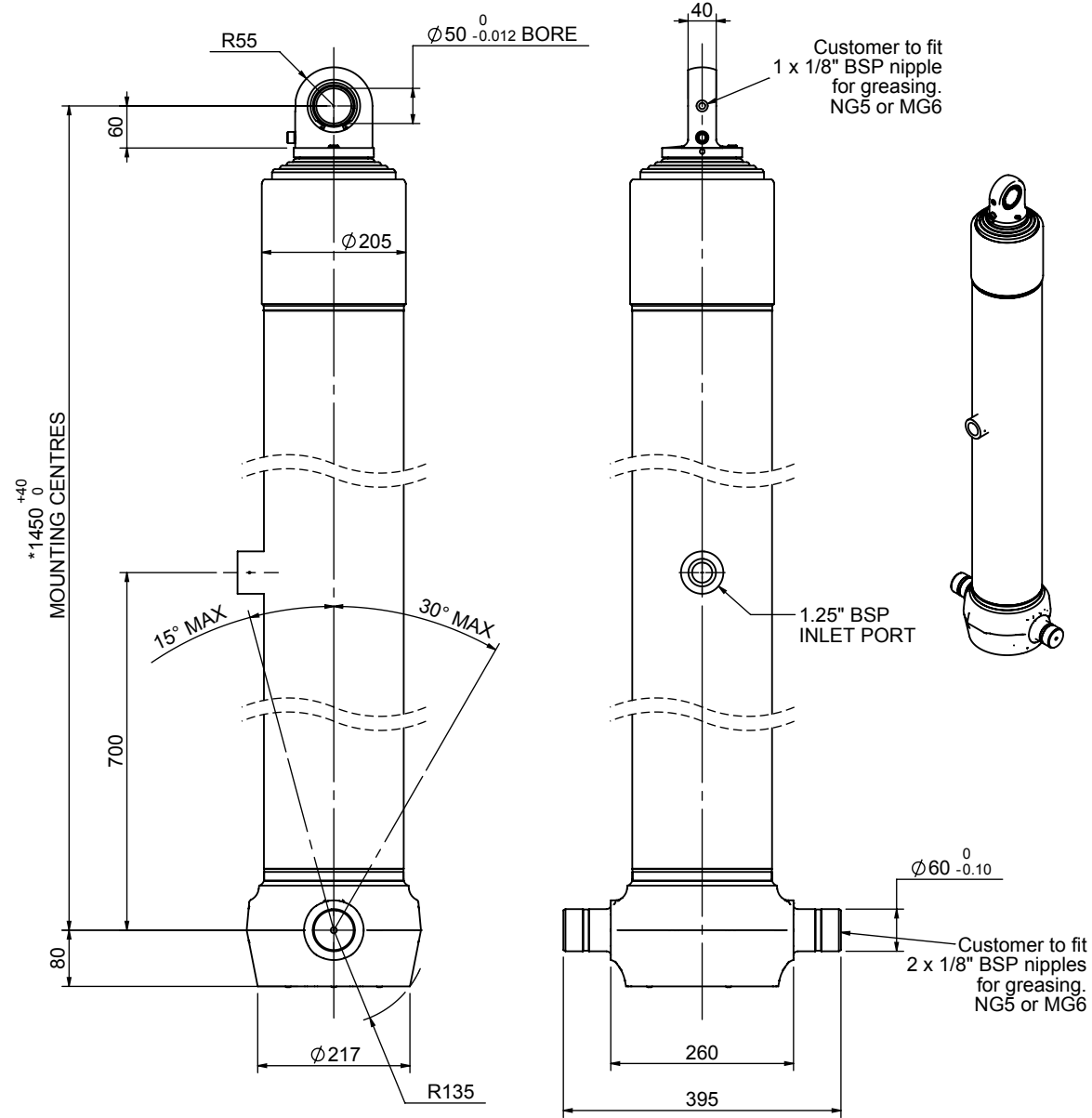

*Includes 9mm Pull Out.
Last Stage Chrome Plated

CS170S55983B70A01

SPECIFICATION		TIPPING CAPACITY : 31-45 TONNES***		
Stage	Diameter	Length	Stroke	Swept Volume
-	-	-	-	-
0	199	1425	-	-
1	176	1390	1167	28
2	155	1390	1187	22
3	136	1390	1197	17
4	117	1390	1212	13
5	98	1390	1217	9
Total (+5/-10)			5980	89
Final stroke reduced by	0	Priming Volume		19
Cylinder Mass (Kg)	216	Total Volume (Litres)		108
Maximum Pressure (Bar)	190	Max. first stage thrust		265 KN

***TIPPING CAPACITY AT WORKING PRESSURE

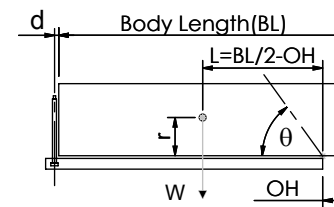

BODY LENGTH (BL)						OH
7500		8000		8500		
35	49°	33	46°	31	43°	150
39	51°	36	48°	34	44°	450
45	54°	40	50°	37	46°	750

d = 0; r = 900; Working Pressure 150 bar

For guidance only;

Higher working pressures and tipping capacities may be possible.

To check your application email - applications@edbro.co.uk

NOTES

1. This cylinder is for lifting purposes only and side load conditions should be avoided
2. Cylinder is painted in primer paint to RAL5013
3. Refer to www.edbro.com for:-
 - Bracket details
 - Installation instructions that must be observed
 - Correct oil selection
 - An explanation of tipping capacity

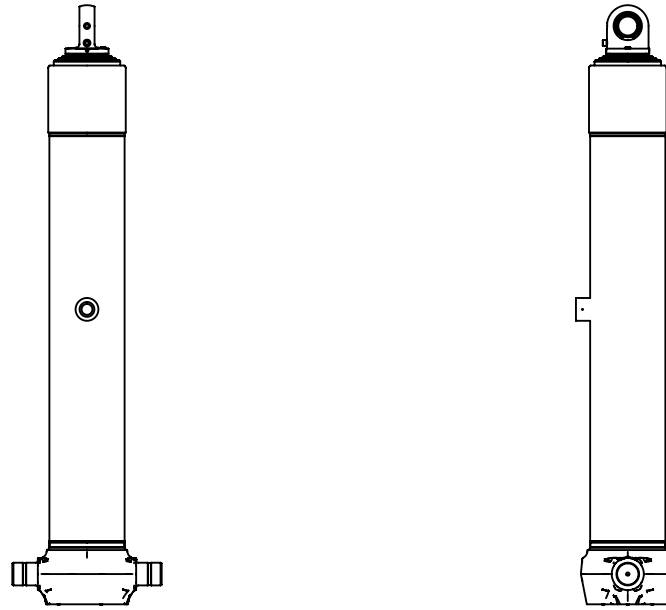

CS170S55983B70A01