

Cylinder 5 stage front end with spherical eye

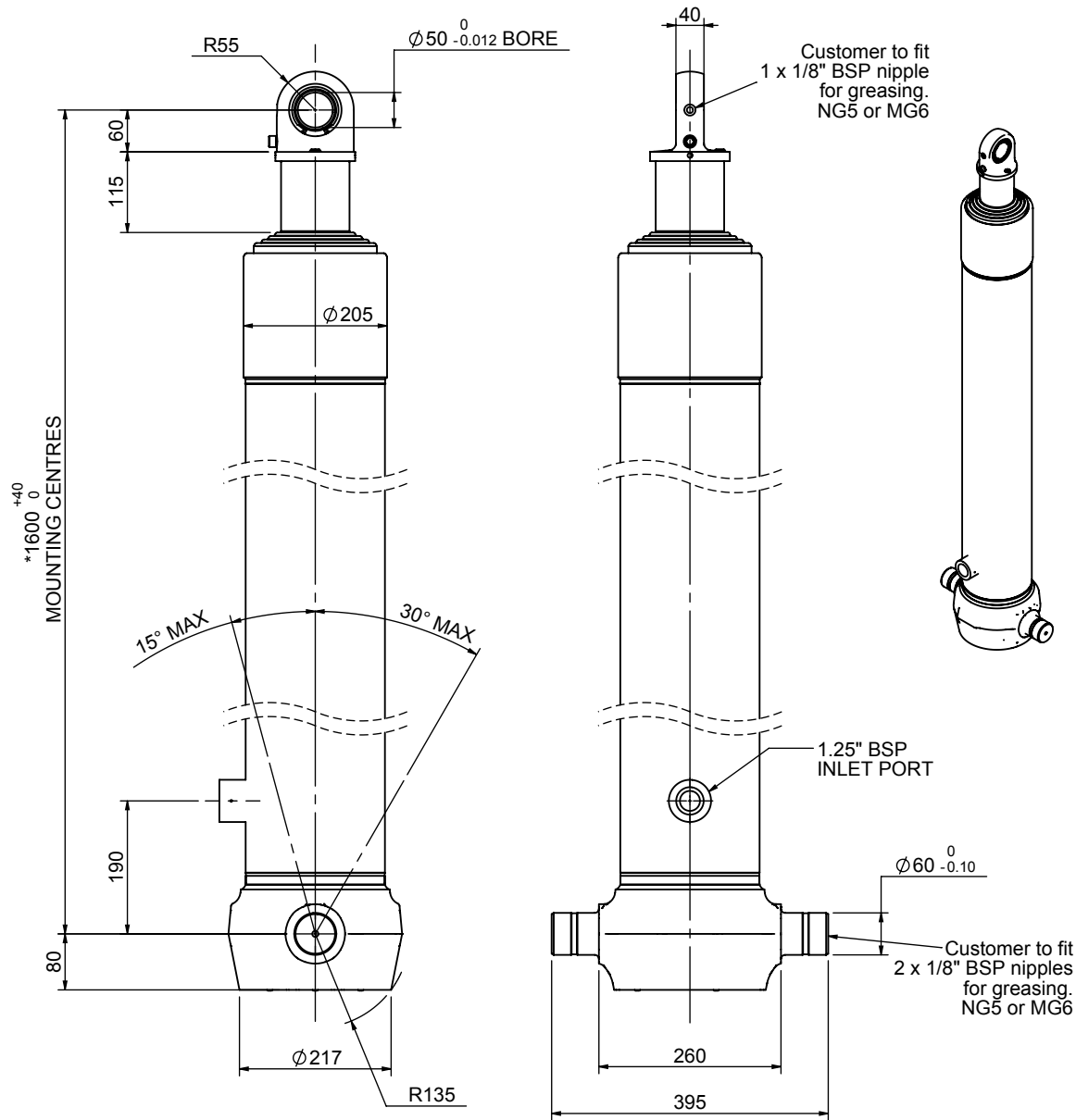

CS170S56233B19A05

SPECIFICATION		TIPPING CAPACITY : 28-40 TONNES***		
Stage	Diameter	Length	Stroke	Swept Volume
-	-	-	-	-
0	199	1475	-	-
1	176	1440	1217	30
2	155	1440	1237	23
3	136	1440	1247	18
4	117	1440	1262	14
5	98	1540	1267	10
Total (+5/-10)			6230	95
Final stroke reduced by	0	Priming Volume	19	
Cylinder Mass (Kg)	223	Total Volume (Litres)	114	
Maximum Pressure (Bar)	190	Max. first stage thrust	265 KN	

***TIPPING CAPACITY AT WORKING PRESSURE

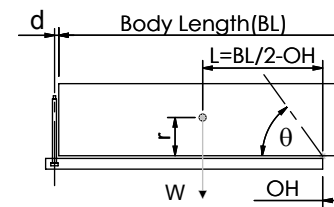

BODY LENGTH (BL)						OH
7750	8250	8750				
32	49°	30	46°	28	43°	150
35	52°	32	48°	30	45°	450
40	54°	36	50°	33	47°	750

$d = 0$; $r = 900$; Working Pressure 135 bar

For guidance only;

Higher working pressures and tipping capacities may be possible.

To check your application email - applications@edbro.co.uk

NOTES

1. This cylinder is for lifting purposes only and side load conditions should be avoided
2. Cylinder is painted in primer paint to RAL5013
3. Refer to www.edbro.com for:-
 - Bracket details
 - Installation instructions that must be observed
 - Correct oil selection
 - An explanation of tipping capacity

*Includes 9mm Pull Out.
Last Stage Chrome Plated

Edbro
SETTING THE INDUSTRY STANDARD

Edbro plc
Nelson Street, Bolton, England, BL3 2JJ
Tel +44 (0) 1204 528888 Fax +44 (0) 1204 531957
Email: postmaster@edbro.com Web: www.edbro.com

Technical Specifications are subject to change without notice
Date Created/Updated: 15 August 2012
Refer www.edbro.com to confirm latest specification
All dimensions are in 'mm', unless otherwise stated

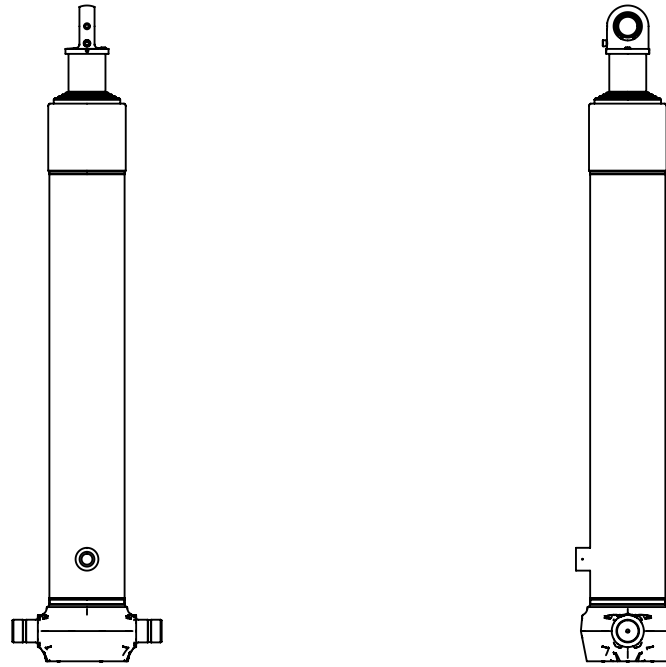

CS170S56233B19A05