

Cylinder 5 stage front end with spherical eye

CS170S56283B70E02

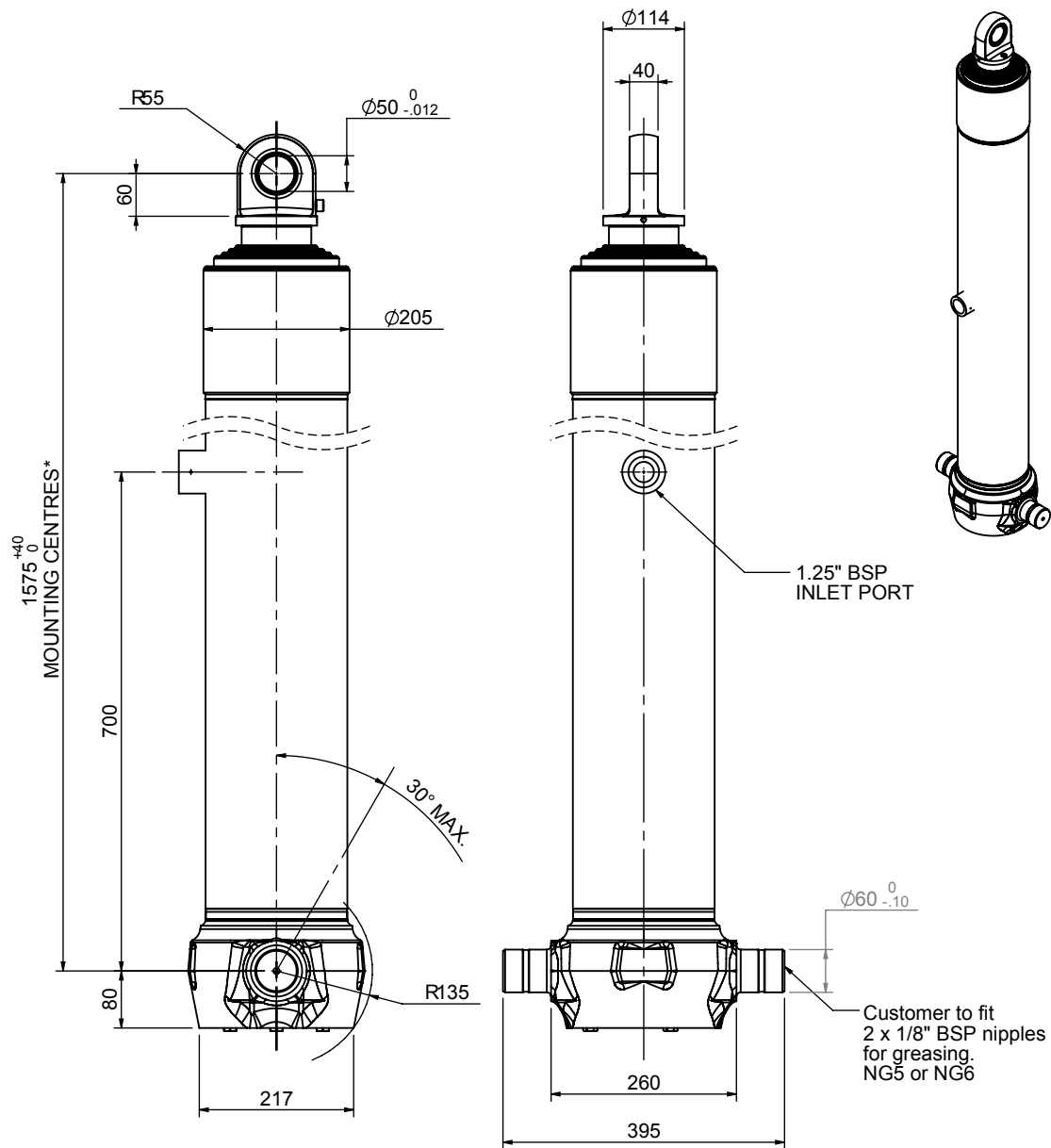

SPECIFICATION RATED CAPACITY : 36-46 TONNES***

Stage	Diameter	Length	Stroke	Swept Volume
-	-	-	-	-
0	199	1525	-	-
1	176	1490	1267	31
2	155	1490	1287	24
3	136	1490	1297	19
4	117	1490	1312	14
5	98	1515	1117	8
Final stroke reduced by	200	Total (+5/-10)	6280	96
Cylinder Mass (Kg)	233.36	Priming Volume	20	
Rated Pressure (Bar)	150	Total Volume (Litres)	116	
Maximum Pressure (Bar)	175	Max. first stage thrust	260 KN	

***TIPPING CAPACITY AT RATED PRESSURE

d = 0 ; r = 900

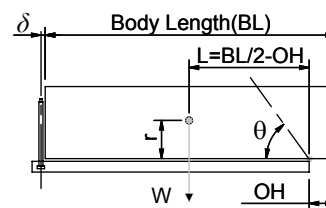

		BODY LENGTH (BL)				OH
		7750	8250	8750		
36	50°					150
40	52°	37	48°			450
46	55°	41	51°	38	47°	750

For guidance only;

Higher Rated Pressures may be possible. To check your application, email Edbro plc at <applications@edbro.co.uk>

NOTES

- If hydraulic pressure is used to limit overloading, the system relief valve must be set to the Rated Pressure unless agreed otherwise by Edbro
- The system relief valve can be set to Maximum Pressure if the load is limited by other means. See RATINGS page for advice
- This cylinder is for lifting purposes only and sload conditions must be avoided
- Cylinder is painted in primer paint to RAL5013
- See bracket options page BRKT01, BRKT02
- See installation instructions INSTALL01
- Use oil according to specification OIL01

*Includes 9mm Pull Out Last Stage Chrome Plated



Edbro plc
 Nelson Street, Bolton, Lancashire BL3 2JJ UK
 Tel +44 (0) 1204 528888 Fax +44 (0) 1204 531957
 Email: postmaster@edbro.com Web: www.edbro.com

Technical Specifications are subject to change without notice
 Date Created/Updated: 13 August 2009 15:53:06
 Refer www.edbro.com to confirm latest specification
 All dimensions are in 'mm', unless otherwise stated