

Cylinder 5 stage front end with spherical eye

CS170S56483B70A01

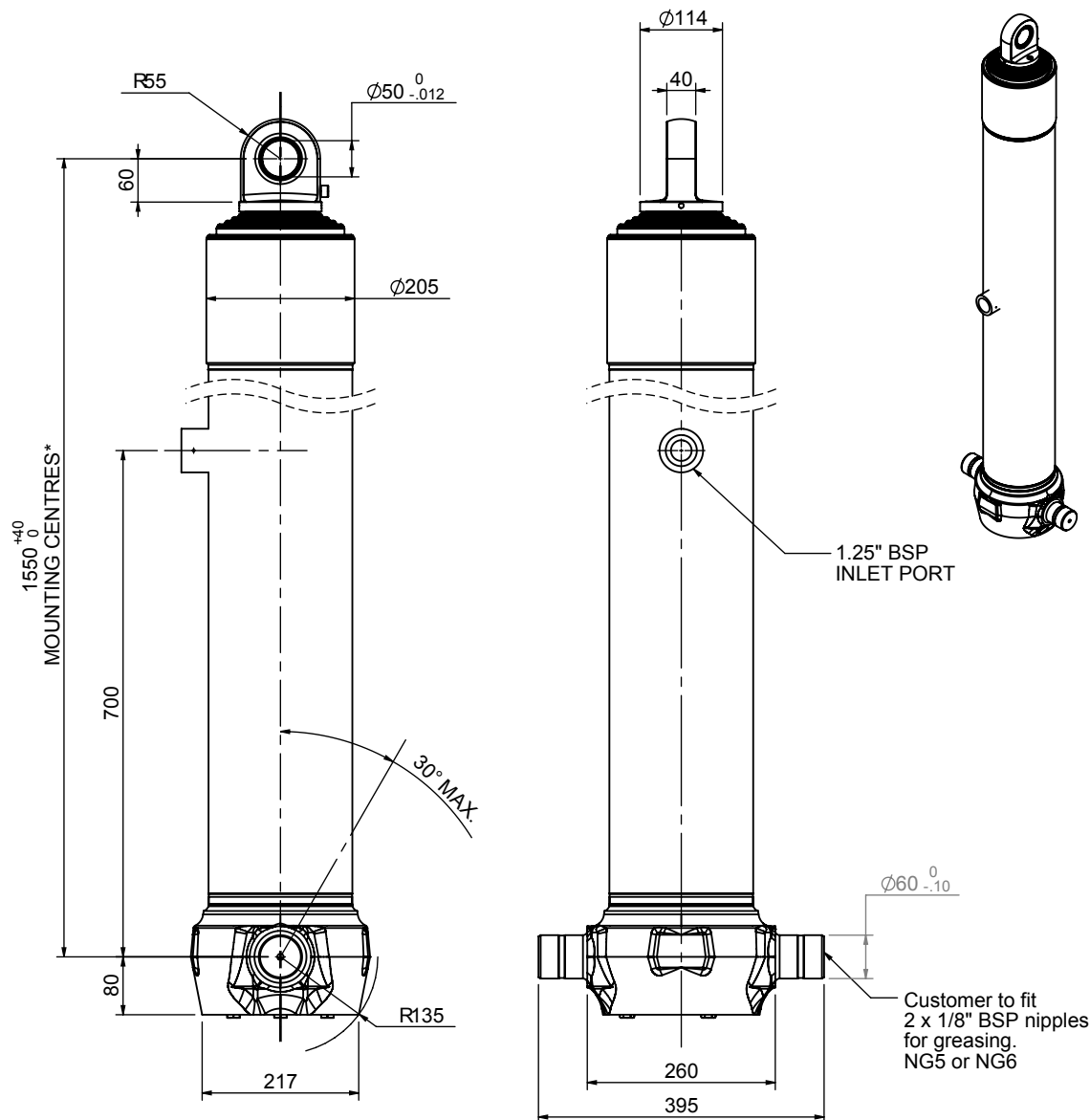

SPECIFICATION RATED CAPACITY : 30-39 TONNES***

Stage	Diameter	Length	Stroke	Swept Volume
-	-	-	-	-
0	199	1525	-	-
1	176	1490	1267	31
2	155	1490	1287	24
3	136	1490	1297	19
4	117	1490	1312	14
5	98	1490	1317	10
Final stroke reduced by	0	Total (+5/-10)	6480	98
Cylinder Mass (Kg)	233.04	Priming Volume	20	
Rated Pressure (Bar)	135	Total Volume (Litres)	118	
Maximum Pressure (Bar)	175	Max. first stage thrust	260 KN	

***TIPPING CAPACITY AT RATED PRESSURE

d = 0 ; r = 900

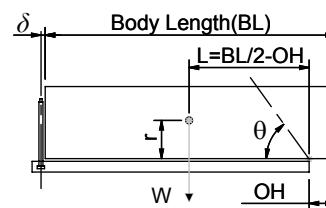

BODY LENGTH (BL)					OH	
8000		8500		9000		
31	50°	30	46°		150	
35	52°	32	48°	30	45°	450
39	54°	35	50°	33	47°	750

Tipping angle (θ)
Body + payload mass, W (tonne)

For guidance only;

Higher Rated Pressures may be possible. To check your application, email Edbro plc at <applications@edbro.co.uk>

NOTES

- If hydraulic pressure is used to limit overloading, the system relief valve must be set to the Rated Pressure unless agreed otherwise by Edbro
- The system relief valve can be set to Maximum Pressure if the load is limited by other means. See RATINGS page for advice
- This cylinder is for lifting purposes only and sload conditions must be avoided
- Cylinder is painted in primer paint to RAL5013
- See bracket options page BRKT01, BRKT02
- See installation instructions INSTALL01
- Use oil according to specification OIL01

*Includes 9mm Pull Out Last Stage Chrome Plated



Edbro plc
Nelson Street, Bolton, Lancashire BL3 2JJ UK
Tel +44 (0) 1204 528888 Fax +44 (0) 1204 531957
Email: postmaster@edbro.com Web: www.edbro.com

Technical Specifications are subject to change without notice
Date Created/Updated: 13 August 2009 15:49:56
Refer www.edbro.com to confirm latest specification
All dimensions are in 'mm', unless otherwise stated