

Cylinder 5 stage front end with spherical eye

CS170S57033B60K02C

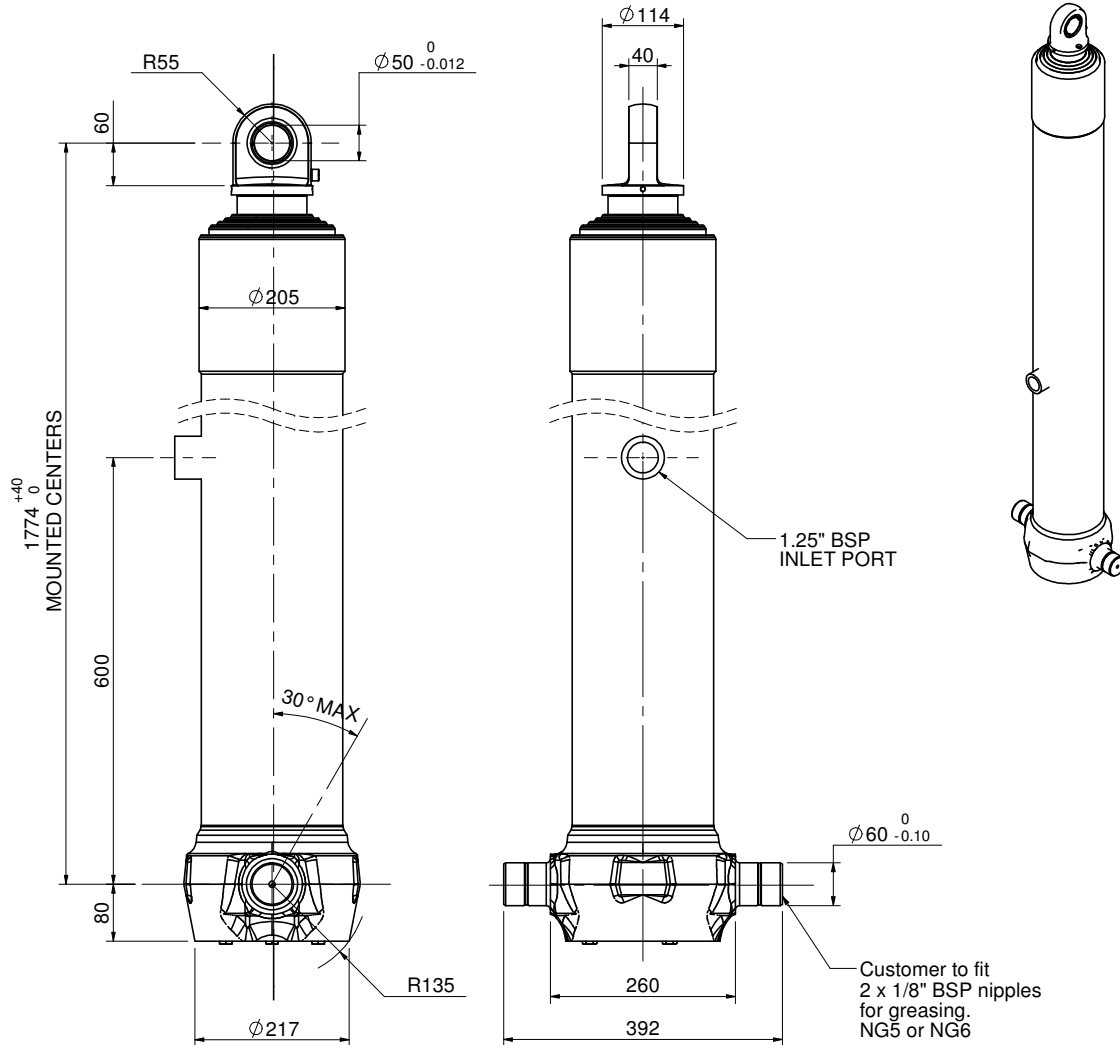

SPECIFICATION		RATED CAPACITY : 25-33 TONNES*		
Stage	Diameter	Length	Stroke	Swept Volume
0	198.12	1725		
1	176.00	1690	1470	35.8
2	154.85	1690	1487	28.0
3	135.75	1690	1497	21.7
4	116.65	1690	1512	16.2
5	97.8	1715	1067	8.0
Final stroke reduced by	450	Total	7033	109.7
Cylinder Mass (Kg)	265	Priming Volume		14.0
Working Pressure (Bar)	120	Total Volume (Litres)		123.7
Maximum Pressure (Bar)	175	Max. first stage thrust		260 KN

*TIPPING CAPACITY AT RATED PRESSURE

$\delta = 0 ; r = 900$

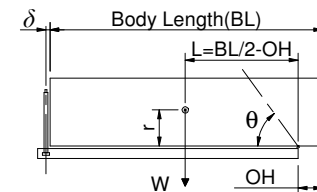

BODY LENGTH (BL)							OH
9000		9500		10000			
27	48°	26	45°	25	42°	150	
30	50°	28	47°	27	44°	450	
33	52°	30	48°	29	45°	750	

Tipping angle (θ)
Body + payload mass, W (tonne)

For guidance only;

Higher working pressures may be possible. To check your application, email Edbro plc at <applications@edbro.co.uk>

NOTES

- If hydraulic pressure is used to limit overloading, the system relief valve must be set to the Working Pressure unless agreed by Edbro.
- The system relief valve can be set to Maximum Pressure if the load is limited by other means.
- This cylinder is for lifting purposes only and sideload conditions must be avoided.
- Cylinder is painted in primer paint to RAL5010.
- See bracket options page 17BRKT01.
- See installation instructions INSTALL01.
- Use oil according to specification OIL01.

This drawing is available on request in PDF (2D), DXF (2D) or Parasolid (3D) via applications@edbro.co.uk

Edbro
SETTING THE INDUSTRY STANDARD

Edbro plc
Nelson Street, Bolton, Lancashire BL3 2JJ UK
Tel +44 (0) 1204 528888 Fax +44 (0) 1204 531957
Email: postmaster@edbro.com Web: www.edbro.com

Technical Specifications are subject to change without notice
Date Created/Updated: 23 January 2009 14:19:25
Refer www.edbro.com to confirm latest specification
All dimensions are in 'mm', unless otherwise stated