

Cylinder 5 stage front end with outer cover

**ALLOW 50mm TO REMOVE CAP FOR SERVICING

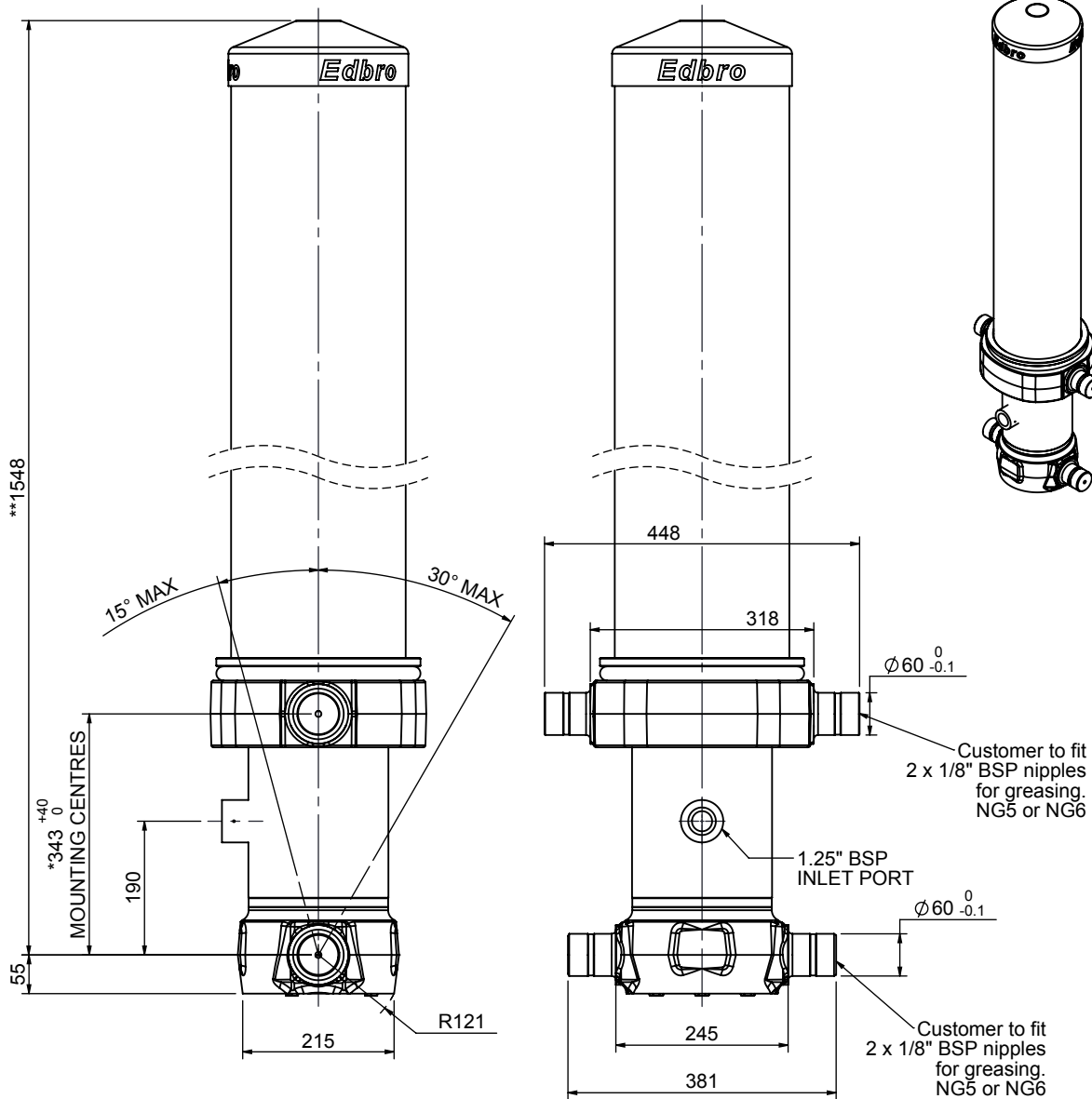

*Includes 7mm Pull Out.
All Stages Chrome Plated

CS17L056233B19A11C

SPECIFICATION

TIPPING CAPACITY : 33-48 TONNES***

Stage	Diameter	Length	Stroke	Swept Volume
OUTER COVER	248	1170	-	-
0	199	1475	-	-
1	176	1440	1220	30
2	155	1440	1237	23
3	136	1440	1247	18
4	117	1440	1262	14
5	98	1440	1267	10
Total (+5/-10)			6233	95
Final stroke reduced by	0	Priming Volume	19.3	
Cylinder Mass (Kg)	271	Total Volume (Litres)	114.3	
Maximum Pressure (Bar)	190	Max. first stage thrust	200 KN	

***TIPPING CAPACITY AT WORKING PRESSURE

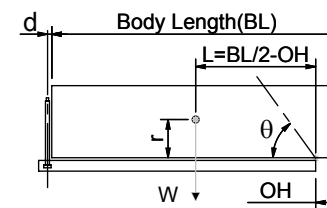

BODY LENGTH (BL)						OH
7500		8000		8500		
37	49°	35	46°	33	43°	150
42	51°	38	47°	36	44°	450
48	53°	42	50°	39	46°	750

d = 229; r = 900; Working Pressure 150 bar

Tipping angle (θ)

Body + payload mass, W (tonne)

For guidance only;

Higher working pressures and tipping capacities may be possible.

To check your application email - applications@edbro.co.uk

NOTES

1. This cylinder is for lifting purposes only and side load conditions should be avoided
2. Cylinder is painted in primer paint to RAL5013
3. Refer to www.edbro.com for:-
 - Bracket details
 - Installation instructions that must be observed
 - Correct oil selection
 - An explanation of tipping capacity

Edbro
SETTING THE INDUSTRY STANDARD

Edbro plc
Nelson Street, Bolton, England, BL3 2JJ
Tel +44 (0) 1204 528888 Fax +44 (0) 1204 531957
Email: postmaster@edbro.com Web: www.edbro.com

Technical Specifications are subject to change without notice
Date Created/Updated: 22 October 2014
Refer www.edbro.com to confirm latest specification
All dimensions are in 'mm', unless otherwise stated

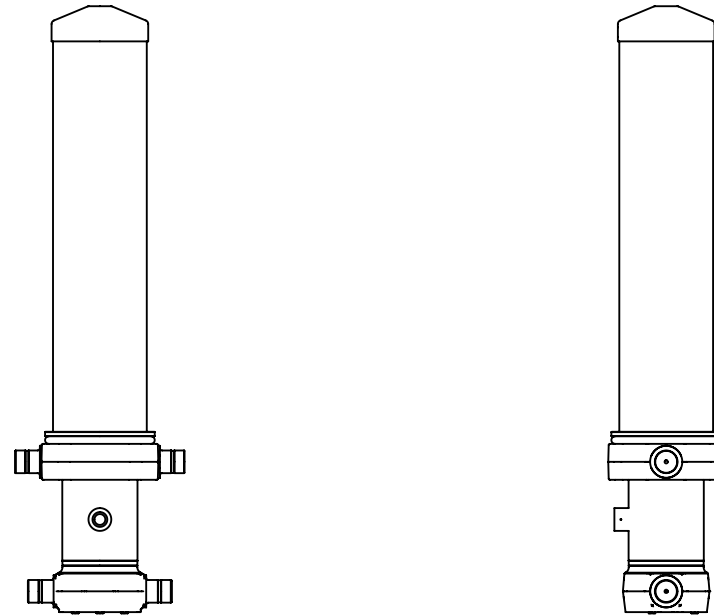

CS17L056233B19A11C