

Cylinder 5 stage front end with outer cover

**ALLOW 50mm TO REMOVE CAP FOR SERVICING

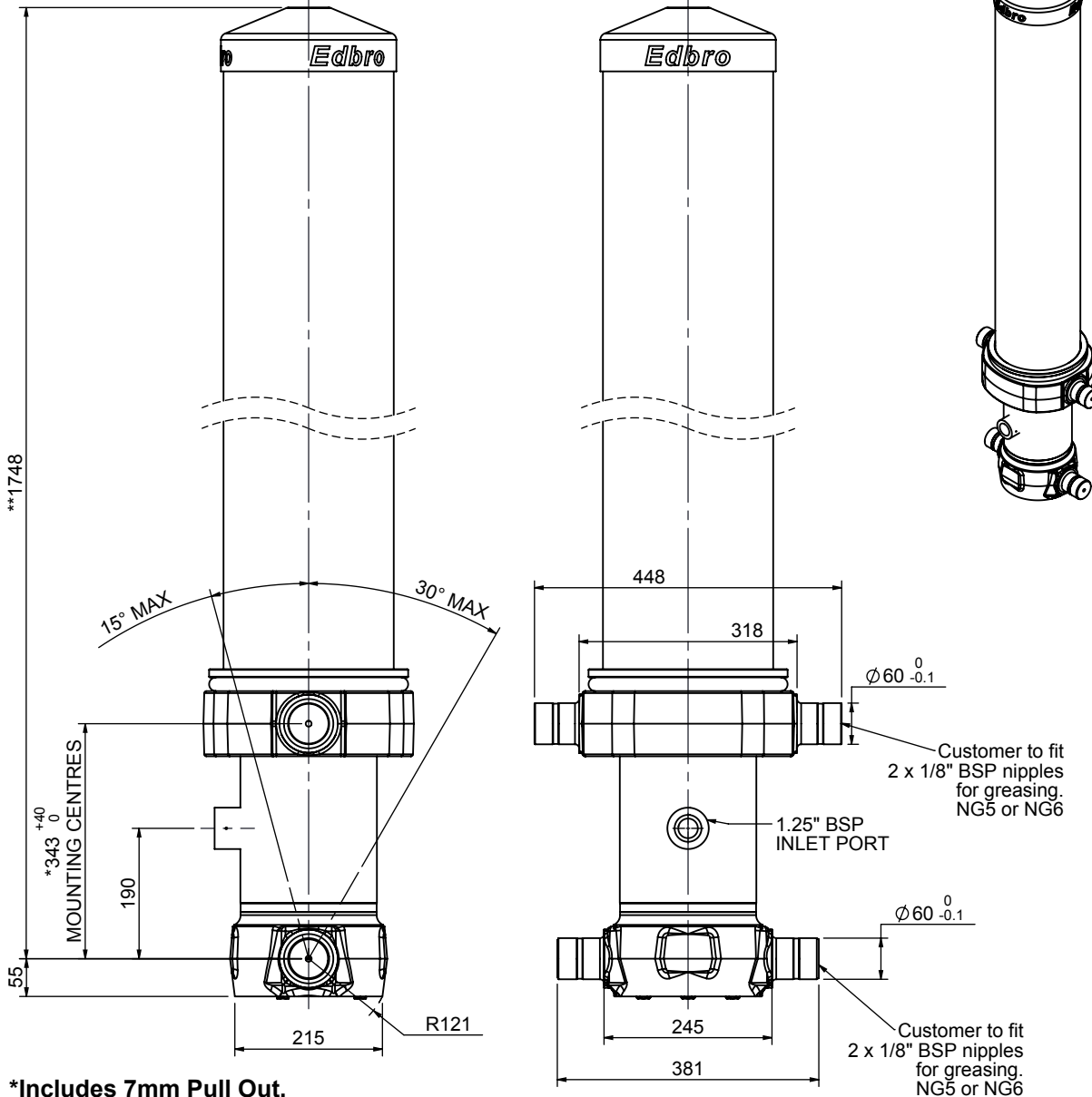

*Includes 7mm Pull Out.

CS17L057233B19A11

SPECIFICATION TIPPING CAPACITY : 33-45 TONNES***

Stage	Diameter	Length	Stroke	Swept Volume
OUTER COVER	248	1370	-	-
0	199	1675	-	-
1	176	1640	1420	35
2	155	1640	1437	27
3	136	1640	1447	21
4	117	1640	1462	16
5	98	1640	1467	11
Total (+5/-10)			7233	110
Final stroke reduced by	0	Priming Volume	22.3	
Cylinder Mass (Kg)	301	Total Volume (Litres)	132.3	
Maximum Pressure (Bar)	190	Max. first stage thrust	200 KN	

***TIPPING CAPACITY AT WORKING PRESSURE

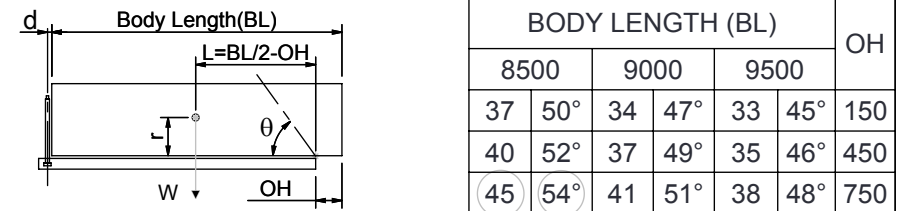

$d = 229$; $r = 900$; Working Pressure 150 bar

For guidance only;

Higher working pressures and tipping capacities may be possible.

To check your application email - applications@edbro.co.uk

NOTES

1. This cylinder is for lifting purposes only and side load conditions should be avoided
2. Cylinder is painted in primer paint to RAL5013
3. Refer to www.edbro.com for:-
 - Bracket details
 - Installation instructions that must be observed
 - Correct oil selection
 - An explanation of tipping capacity

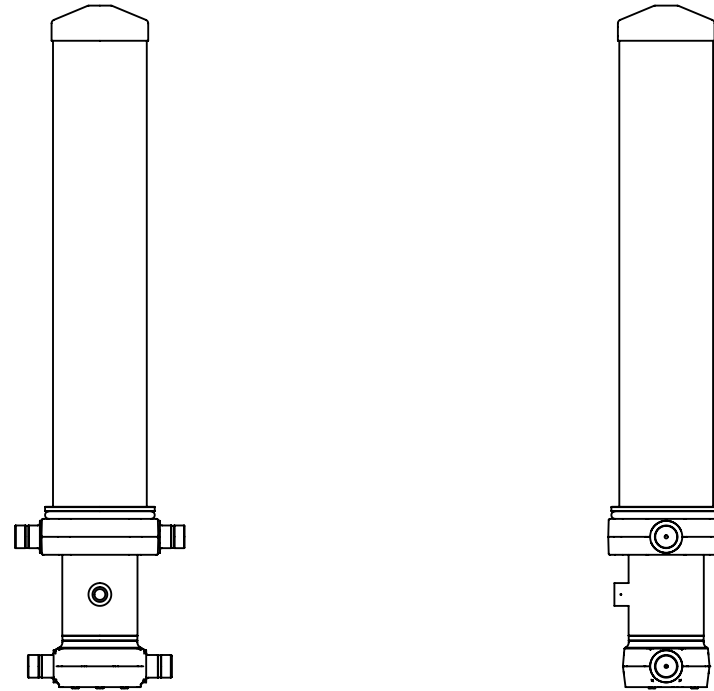

CS17L057233B19A11