

Cylinder 5 stage front end with outer cover

**ALLOW 50mm TO REMOVE CAP FOR SERVICING

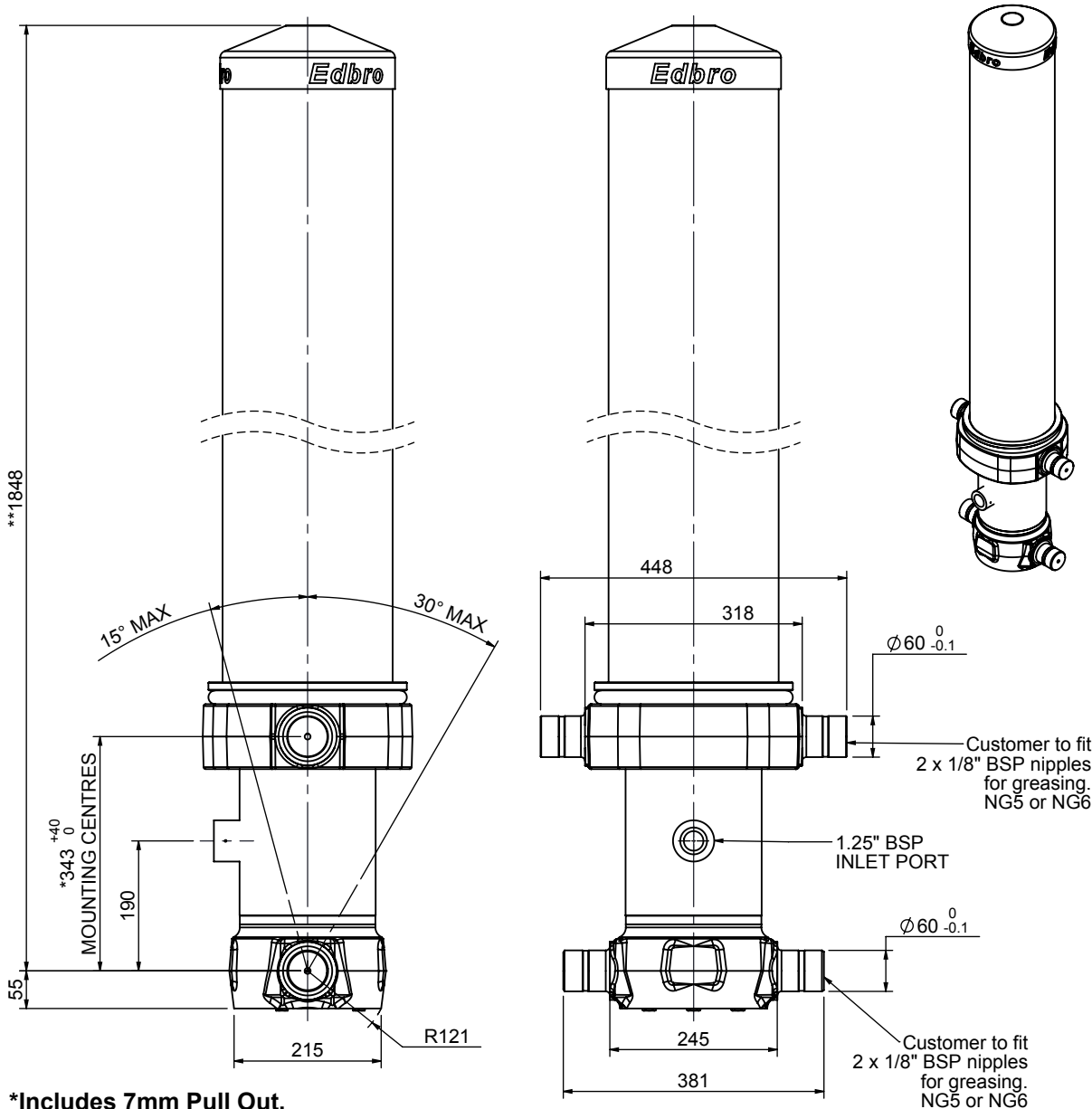

*Includes 7mm Pull Out.
All Stages Chrome Plated

CS17L057733B19A11C

SPECIFICATION

TIPPING CAPACITY : 33-44 TONNES***

Stage	Diameter	Length	Stroke	Swept Volume
OUTER COVER	248	1470	-	-
0	199	1775	-	-
1	176	1740	1520	37
2	155	1740	1537	29
3	136	1740	1547	22
4	117	1740	1562	17
5	98	1740	1567	12
Total (+5/-10)			7733	117
Final stroke reduced by	0	Priming Volume		23.8
Cylinder Mass (Kg)	321	Total Volume (Litres)		140.8
Maximum Pressure (Bar)	190	Max. first stage thrust		200 KN

***TIPPING CAPACITY AT WORKING PRESSURE

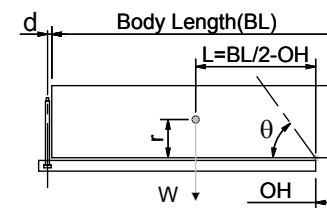

BODY LENGTH (BL)						OH
9000		9500		10000		
36	51°	34	48°	33	45°	150
39	53°	37	49°	35	47°	450
44	55°	40	51°	38	48°	750

d = 229; r = 900; Working Pressure 150 bar

For guidance only;

Higher working pressures and tipping capacities may be possible.

To check your application email - applications@edbro.co.uk

NOTES

1. This cylinder is for lifting purposes only and side load conditions should be avoided
2. Cylinder is painted in primer paint to RAL5013
3. Refer to www.edbro.com for;-
 - Bracket details
 - Installation instructions that must be observed
 - Correct oil selection
 - An explanation of tipping capacity

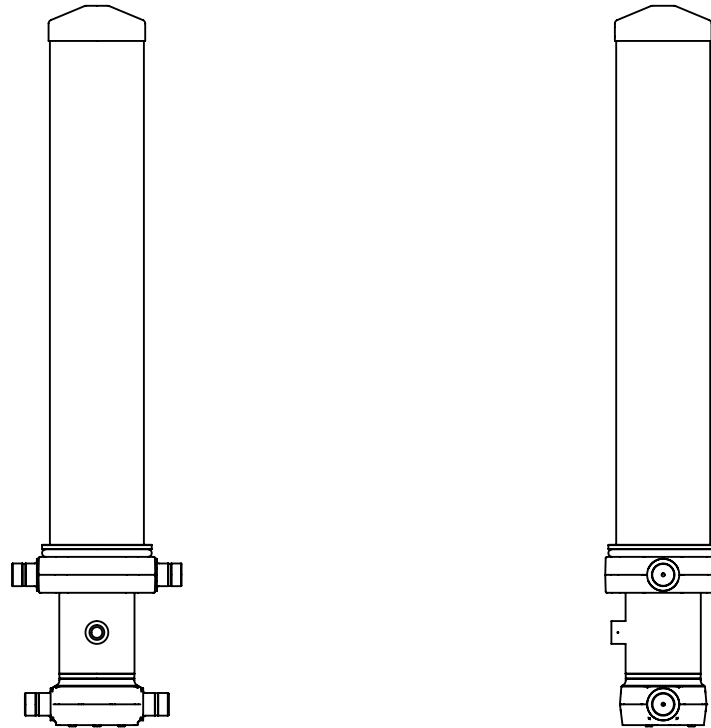

CS17L057733B19A11C