

Cylinder 5 stage front end with Outer Cover

****ALLOW 50mm TO REMOVE CAP FOR SERVICING**

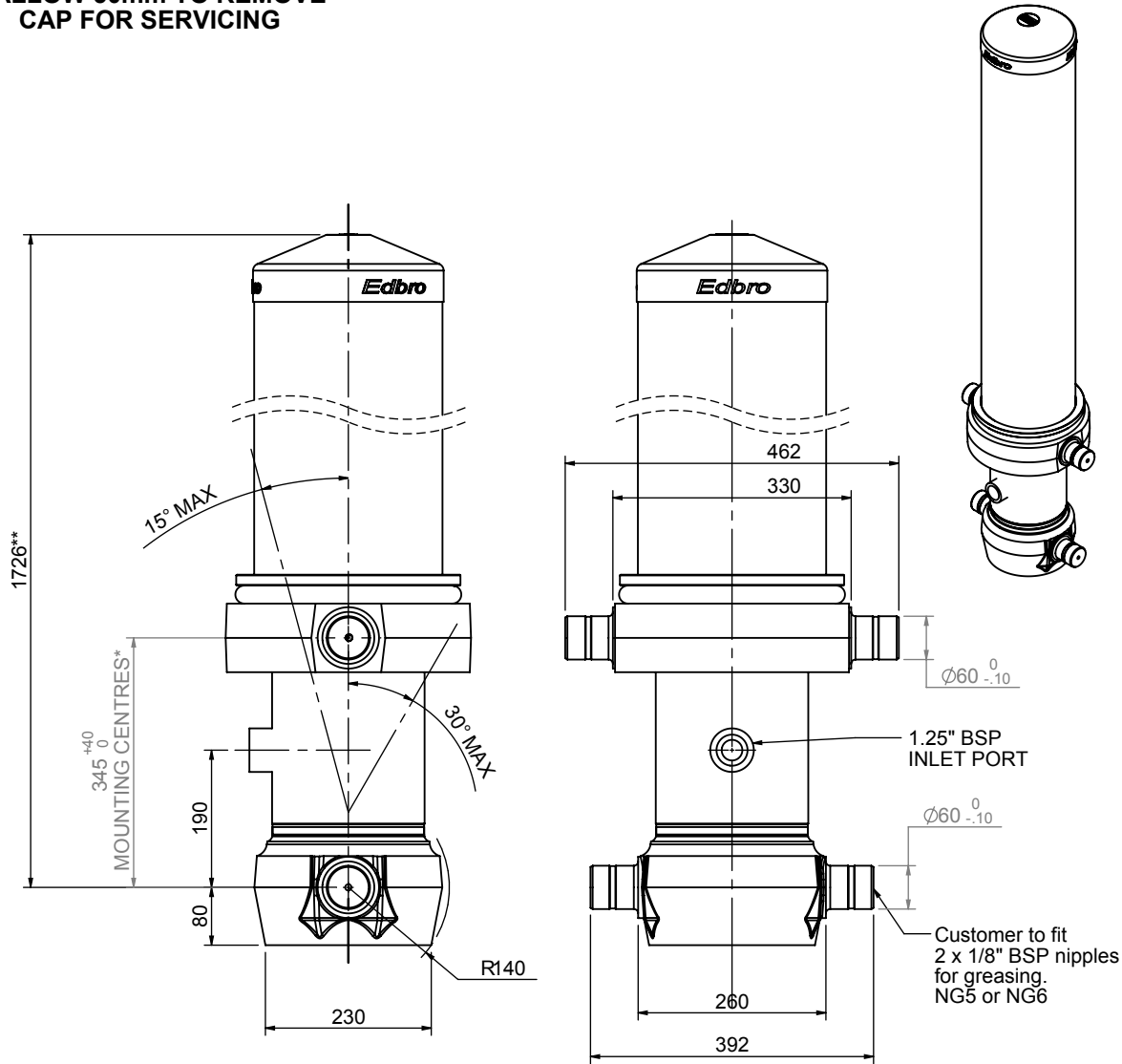

CS180057233B19A11

SPECIFICATION		RATED CAPACITY : 44-60 TONNES***		
Stage	Diameter	Length	Stroke	Swept Volume
OUTER COVER	261	1345	-	-
0	211	1675	-	-
1	188	1640	1414	39
2	167	1640	1437	31
3	147	1640	1447	25
4	127	1640	1462	19
5	105	1640	1467	13
Final stroke reduced by	0	Total (+5/-10)	7227	127
Cylinder Mass (Kg)	371.72	Priming Volume	23	
Rated Pressure (Bar)	175	Total Volume (Litres)	150	
Maximum Pressure (Bar)	175	Max. first stage thrust	260 KN	

***TIPPING CAPACITY AT RATED PRESSURE

d = 229 ; r = 900

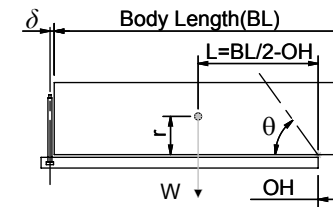

BODY LENGTH (BL)						OH
8500		9000		9500		
49	50°	46	47°	44	45°	150
54	52°	50	49°	47	46°	450
60	54°	55	51°	51	48°	750

— Tipping angle (θ)
 — Body + payload mass, W (tonne)

For guidance only;

Higher Rated Pressures may be possible. To check your application, email Edbro plc at <applications@edbro.co.uk>

NOTES

- If hydraulic pressure is used to limit overloading, the system relief valve must be set to the Rated Pressure unless agreed otherwise by Edbro
- The system relief valve can be set to Maximum Pressure if the load is limited by other means. See RATINGS page for advice
- This cylinder is for lifting purposes only and sload conditions must be avoided
- Cylinder is painted in primer paint to RAL5013
- See bracket options page BRKT01, BRKT02
- See installation instructions INSTALL01
- Use oil according to specification OIL01

*Includes 12mm Pull Out

Edbro
SETTING THE INDUSTRY STANDARD

Edbro plc
Nelson Street, Bolton, Lancashire BL3 2JJ UK
Tel +44 (0) 1204 528888 Fax +44 (0) 1204 531957
Email: postmaster@edbro.com Web: www.edbro.com

Technical Specifications are subject to change without notice
Date Created/Updated: 26 August 2009 14:57:58
Refer www.edbro.com to confirm latest specification
All dimensions are in 'mm', unless otherwise stated