

Cylinder 5 stage front end with outer cover

****ALLOW 50mm TO REMOVE CAP FOR SERVICING**

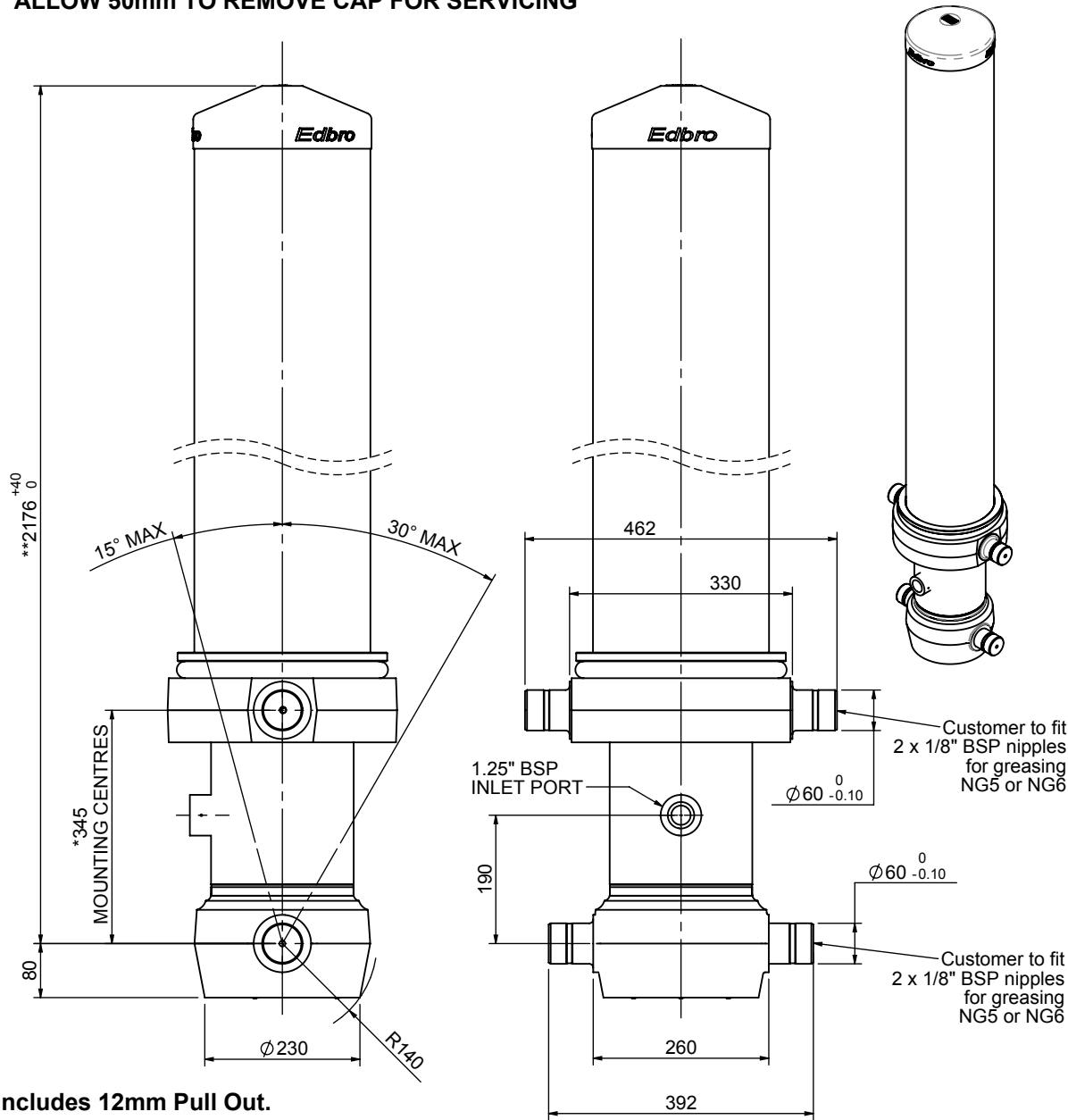

*Includes 12mm Pull Out.

CS180059483B19A11

SPECIFICATION		TIPPING CAPACITY : 29-36 TONNES***		
Stage	Diameter	Length	Stroke	Swept Volume
OUTER COVER	261	1795	-	-
0	211	2125	-	-
1	188	2090	1865	52
2	167	2090	1887	41
3	147	2090	1897	32
4	127	2090	1912	24
5	105	2090	1917	17
Total (+5/-10)			9478	166
Final stroke reduced by	0	Priming Volume		31
Cylinder Mass (Kg)	452	Total Volume (Litres)		197
Maximum Pressure (Bar)	190	Max. first stage thrust		265 KN

***TIPPING CAPACITY AT WORKING PRESSURE

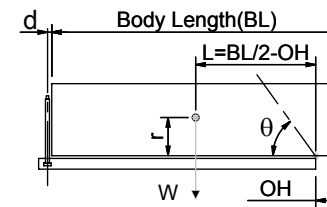

BODY LENGTH (BL)						OH
11000	11500	12000				
32	51°	31	49°	29	46°	150
34	52°	32	50°	31	48°	450
36	54°	34	51°	33	49°	750

d = 229; r = 900; Working Pressure 120 bar

For guidance only;

Higher working pressures and tipping capacities may be possible.

To check your application email - applications@edbro.co.uk

NOTES

1. This cylinder is for lifting purposes only and side load conditions should be avoided
2. Cylinder is painted in primer paint to RAL5013
3. Refer to www.edbro.com for:-
 - Bracket details
 - Installation instructions that must be observed
 - Correct oil selection
 - An explanation of tipping capacity

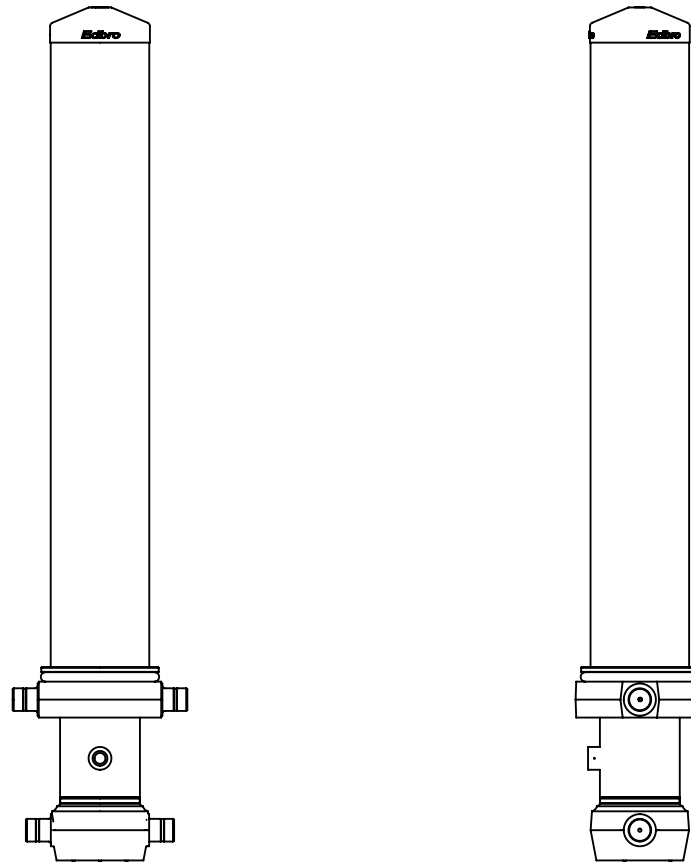

CS180059483B19A11