

Cylinder 4 stage front end with plain eye

CS180E45166B19A01

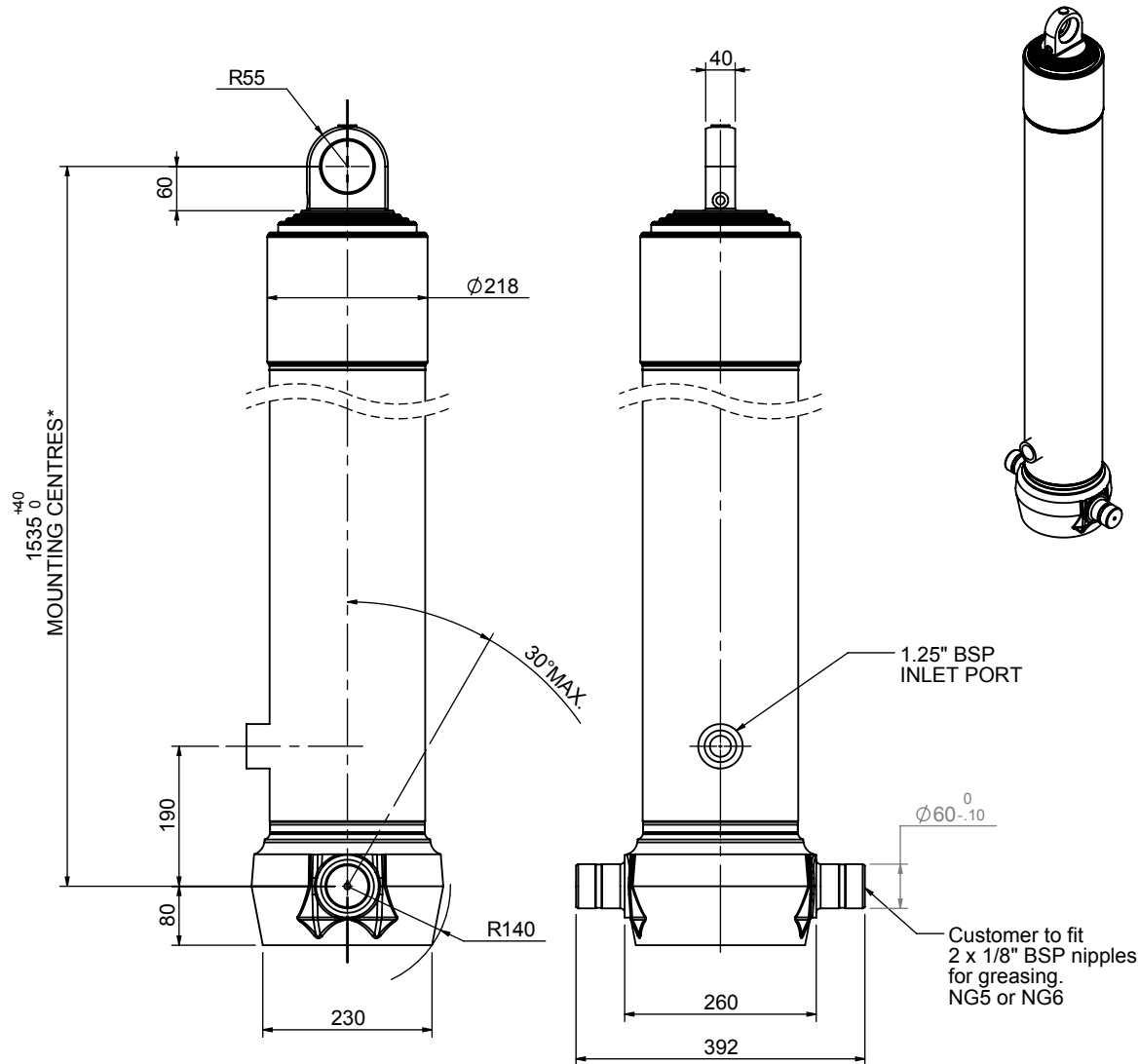

SPECIFICATION		RATED CAPACITY : 46-59 TONNES**		
Stage	Diameter	Length	Stroke	Swept Volume
-	-	-	-	-
-	-	-	-	-
0	211	1525	-	-
1	188	1490	1267	35
2	167	1490	1287	28
3	147	1490	1297	22
4	127	1490	1312	17
Final stroke reduced by	0	Total (+5/-10)	5163	102
Cylinder Mass (Kg)	241.96	Priming Volume	24	
Rated Pressure (Bar)	135	Total Volume (Litres)	126	
Maximum Pressure (Bar)	175	Max. first stage thrust	260 KN	

**TIPPING CAPACITY AT RATED PRESSURE

$d = 0 ; r = 900$

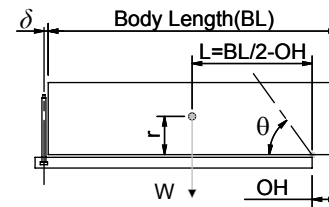

	BODY LENGTH (BL)						OH
	6750		7250		7750		
51	47°	48	43°	46	40°	150	
57	49°	52	45°	49	42°	450	
XX	YY°	59	48°	54	44°	750	

Tipping angle (θ)
Body + payload mass, W (tonne)

For guidance only;

Higher Rated Pressures may be possible. To check your application, email Edbro plc at <applications@edbro.co.uk>

NOTES

- If hydraulic pressure is used to limit overloading, the system relief valve must be set to the Rated Pressure unless agreed otherwise by Edbro
- The system relief valve can be set to Maximum Pressure if the load is limited by other means. See RATINGS page for advice
- This cylinder is for lifting purposes only and sload conditions must be avoided
- Cylinder is painted in primer paint to RAL5013
- See bracket options page BRKT01, BRKT02
- See installation instructions INSTALL01
- Use oil according to specification OIL01

*Includes 9mm Pull Out Last Stage Chrome Plated

Edbro
SETTING THE INDUSTRY STANDARD

Edbro plc
Nelson Street, Bolton, Lancashire BL3 2JJ UK
Tel +44 (0) 1204 528888 Fax +44 (0) 1204 531957
Email: postmaster@edbro.com Web: www.edbro.com

Technical Specifications are subject to change without notice
Date Created/Updated: 12 August 2009 09:06:32
Refer www.edbro.com to confirm latest specification
All dimensions are in 'mm', unless otherwise stated