

Cylinder 4 stage front end with plain eye

CS180E46966B19A01

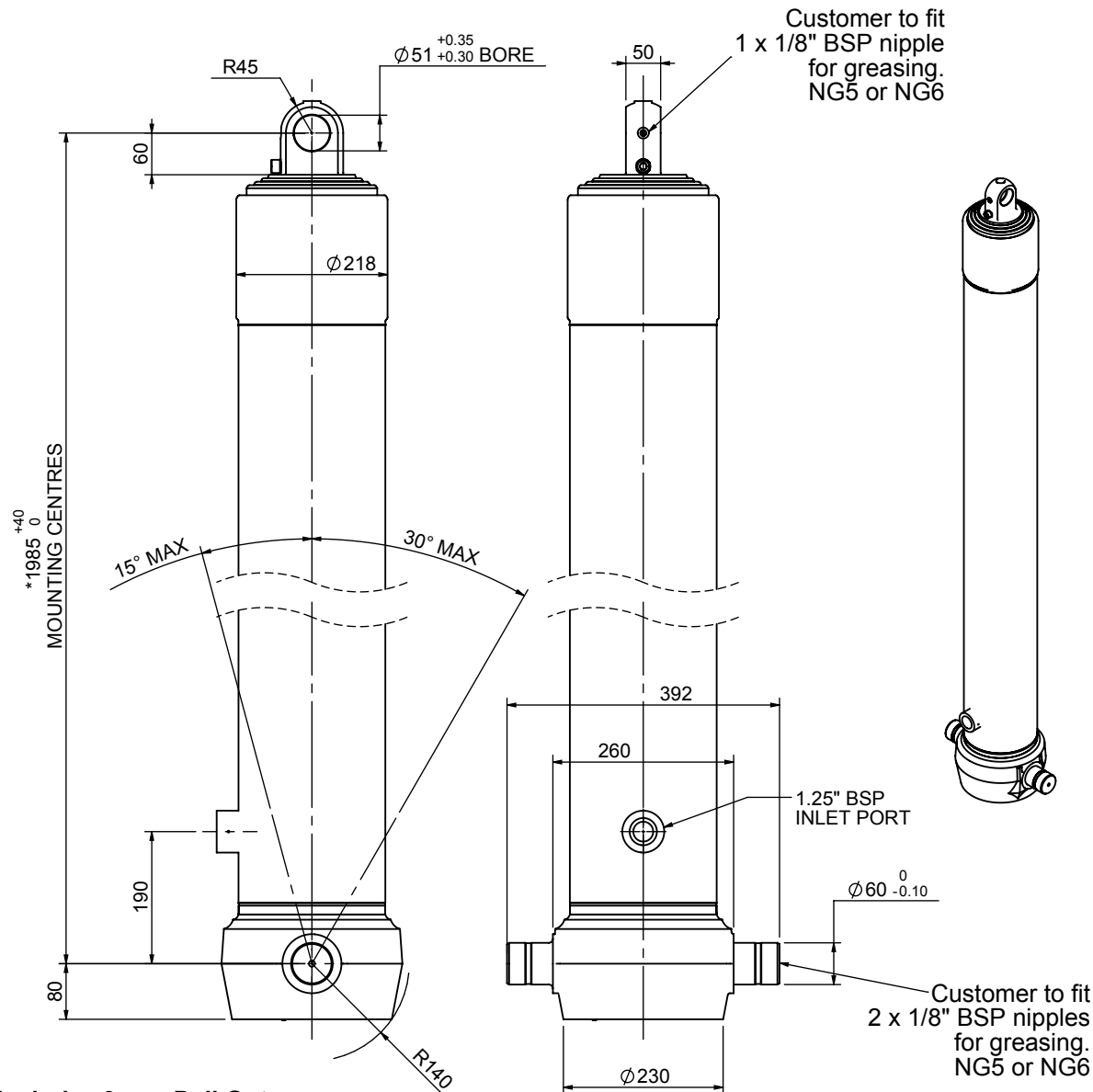

SPECIFICATION		TIPPING CAPACITY : 39-47 TONNES***		
Stage	Diameter	Length	Stroke	Swept Volume
-	-	-	-	-
-	-	-	-	-
0	211	1975	-	-
1	188	1940	1718	48
2	167	1940	1737	38
3	147	1940	1747	30
4	127	1940	1762	22
Total (+5/-10)			8382	138
Final stroke reduced by	0	Priming Volume		32
Cylinder Mass (Kg)	301	Total Volume (Litres)		170
Maximum Pressure (Bar)	190	Max. first stage thrust		265 KN

***TIPPING CAPACITY AT WORKING PRESSURE

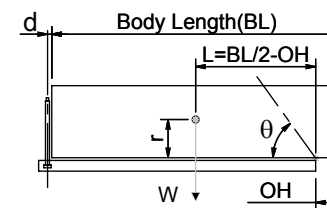

BODY LENGTH (BL)						OH
9000		9500		10000		
41	47°	40	45°	39	42°	150
44	49°	42	46°	41	43°	450
47	51°	45	48°	43	45°	750

d = 0; r = 750; Working Pressure 120 bar
For guidance only;
 Higher working pressures and tipping capacities may be possible.
 To check your application email - applications@edbro.co.uk

NOTES

- This cylinder is for lifting purposes only and side load conditions should be avoided
- Cylinder is painted in primer paint to RAL5013
- Refer to www.edbro.com for:-
 - Bracket details
 - Installation instructions that must be observed
 - Correct oil selection
 - An explanation of tipping capacity

*Includes 9 mm Pull Out.
 Last Stage Chrome Plated



Edbro plc
 Nelson Street, Bolton, England, BL3 2JJ
 Tel +44 (0) 1204 528888 Fax +44 (0) 1204 531957
 Email: postmaster@edbro.com Web: www.edbro.com

Technical Specifications are subject to change without notice
 Date Created/Updated: 20 August 2012
 Refer www.edbro.com to confirm latest specification
 All dimensions are in 'mm', unless otherwise stated

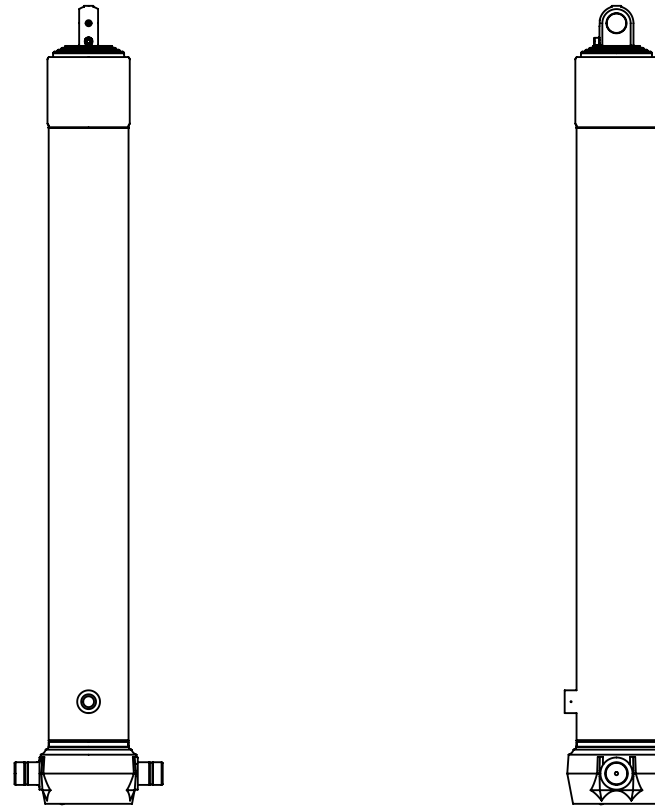

CS180E46966B19A01