

Cylinder 5 stage front end with plain eye

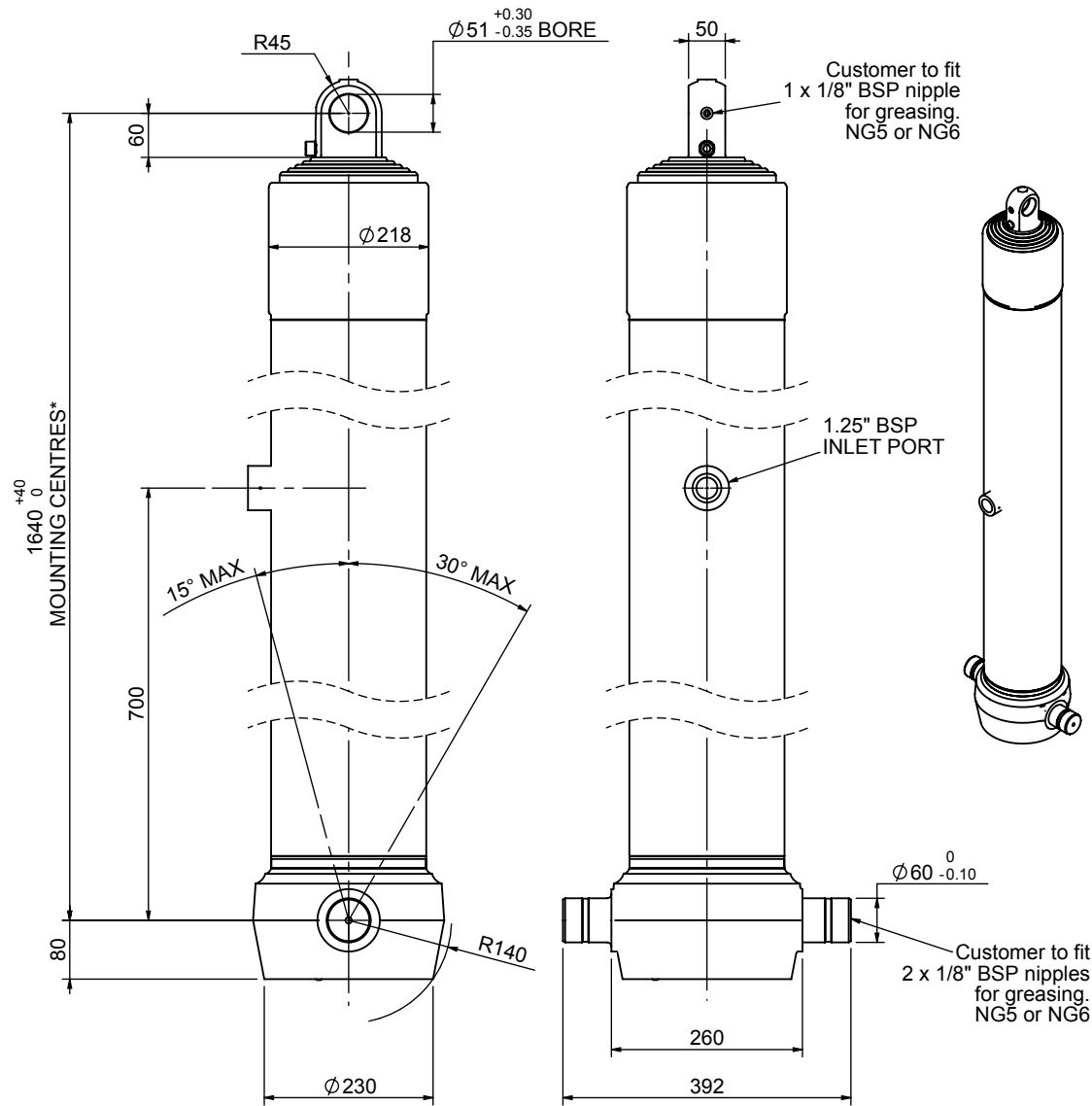

*Includes 9mm Pull Out.
Last Stage Chrome Plated

CS180E56983B70A01

SPECIFICATION		TIPPING CAPACITY : 31-38 TONNES***		
Stage	Diameter	Length	Stroke	Swept Volume
-	-	-	-	-
0	211	1625	-	-
1	188	1590	1368	38
2	167	1590	1387	30
3	147	1590	1397	24
4	127	1590	1412	18
5	105	1590	1417	12
Total (+5/-10)			6981	122
Final stroke reduced by	0	Priming Volume		23
Cylinder Mass (Kg)	282	Total Volume (Litres)		145
Maximum Pressure (Bar)	190	Max. first stage thrust		265 KN

***TIPPING CAPACITY AT WORKING PRESSURE

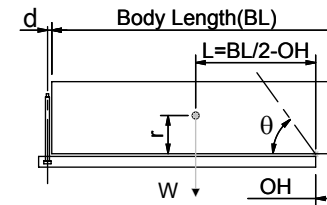

BODY LENGTH (BL)						OH
9000		9500		10000		
33	47°	32	45°	31	42°	150
35	49°	34	46°	32	43°	450
38	51°	36	48°	34	45°	750

d = 0; r = 750; Working Pressure 135 bar

For guidance only;

Higher working pressures and tipping capacities may be possible.

To check your application email - applications@edbro.co.uk

NOTES

1. This cylinder is for lifting purposes only and side load conditions should be avoided
2. Cylinder is painted in primer paint to RAL5013
3. Refer to www.edbro.com for:-
 - Bracket details
 - Installation instructions that must be observed
 - Correct oil selection
 - An explanation of tipping capacity

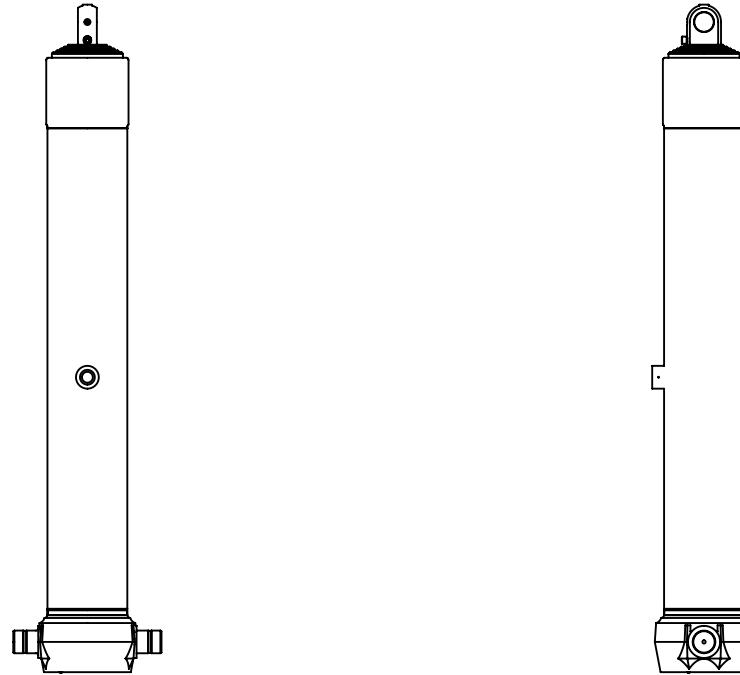

CS180E56983B70A01