

# Cylinder 5 stage front end with plain eye

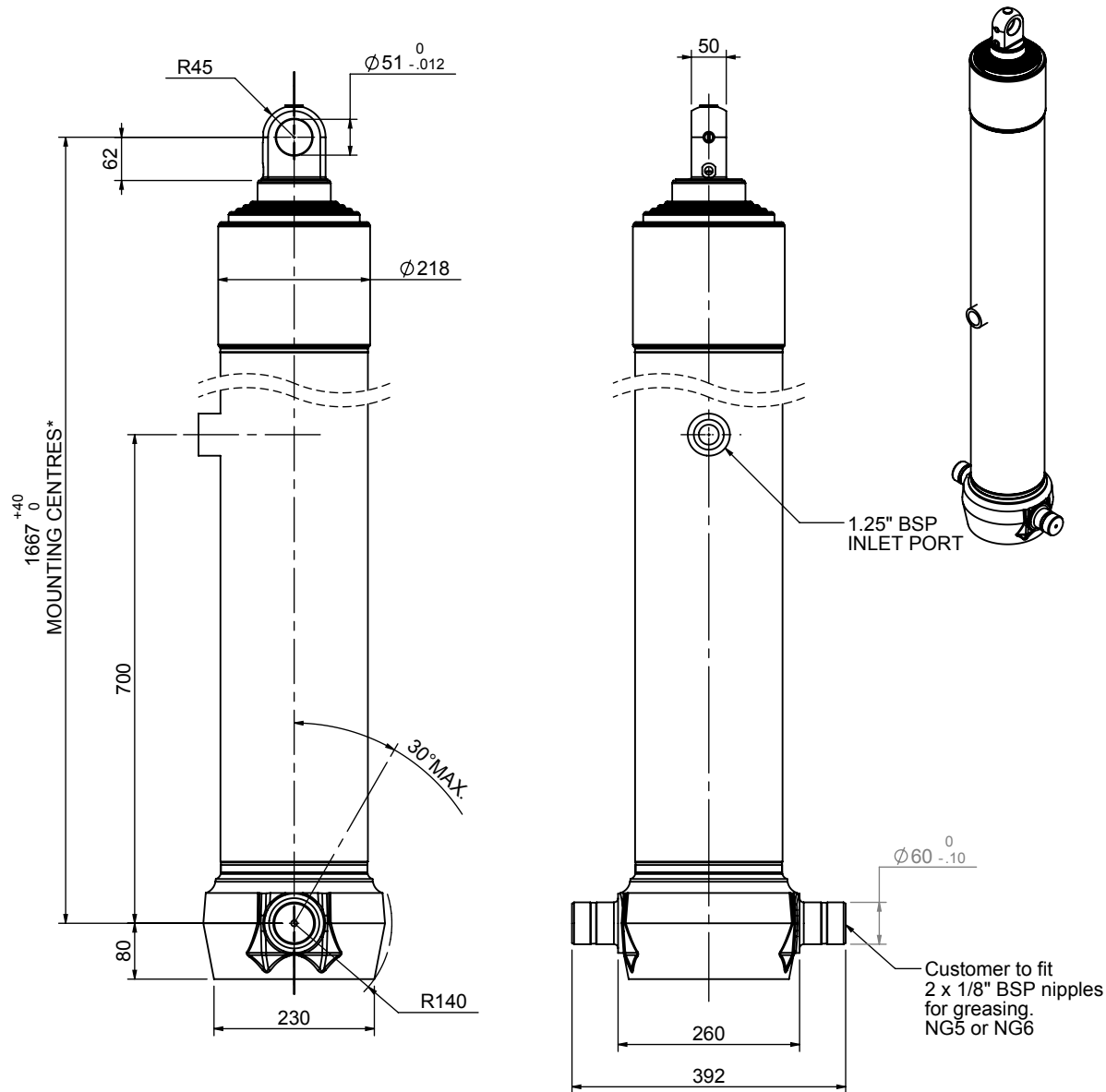

\*Includes 9mm Pull Out  
All Stages Chrome Plated

# CS180E56983B70A02C

SPECIFICATION		RATED CAPACITY : 32-42 TONNES**		
Stage	Diameter	Length	Stroke	Swept Volume
-	-	-	-	-
0	211	1625	-	-
1	188	1590	1367	38
2	167	1590	1387	30
3	147	1590	1397	24
4	127	1590	1412	18
5	105	1615	1417	12
Final stroke reduced by	0	Total (+5/-10)	6980	122
Cylinder Mass (Kg)	283.86	Priming Volume	23	
Rated Pressure (Bar)	135	Total Volume (Litres)	145	
Maximum Pressure (Bar)	175	Max. first stage thrust	260 KN	

### \*\*TIPPING CAPACITY AT RATED PRESSURE

d = 0 ; r = 900

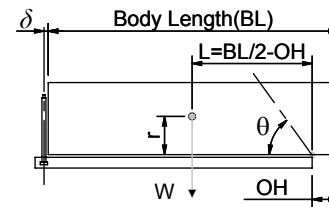

BODY LENGTH (BL)					OH	
8750		9250		9750		
35	49°	33	46°	32	43°	150
38	51°	36	48°	34	45°	450
42	53°	39	49°	36	46°	750

— Tipping angle (θ)  
— Body + payload mass, W (tonne)

**For guidance only;**  
Higher Rated Pressures may be possible. To check your application, email Edbro plc at <applications@edbro.co.uk>

### NOTES

- If hydraulic pressure is used to limit overloading, the system relief valve must be set to the Rated Pressure unless agreed otherwise by Edbro
- The system relief valve can be set to Maximum Pressure if the load is limited by other means. See RATINGS page for advice
- This cylinder is for lifting purposes only and sload conditions must be avoided
- Cylinder is painted in primer paint to RAL5013
- See bracket options page BRKT01, BRKT02
- See installation instructions INSTALL01
- Use oil according to specification OIL01