

# Cylinder 5 stage front end with plain eye

## CS180E57633S70A01

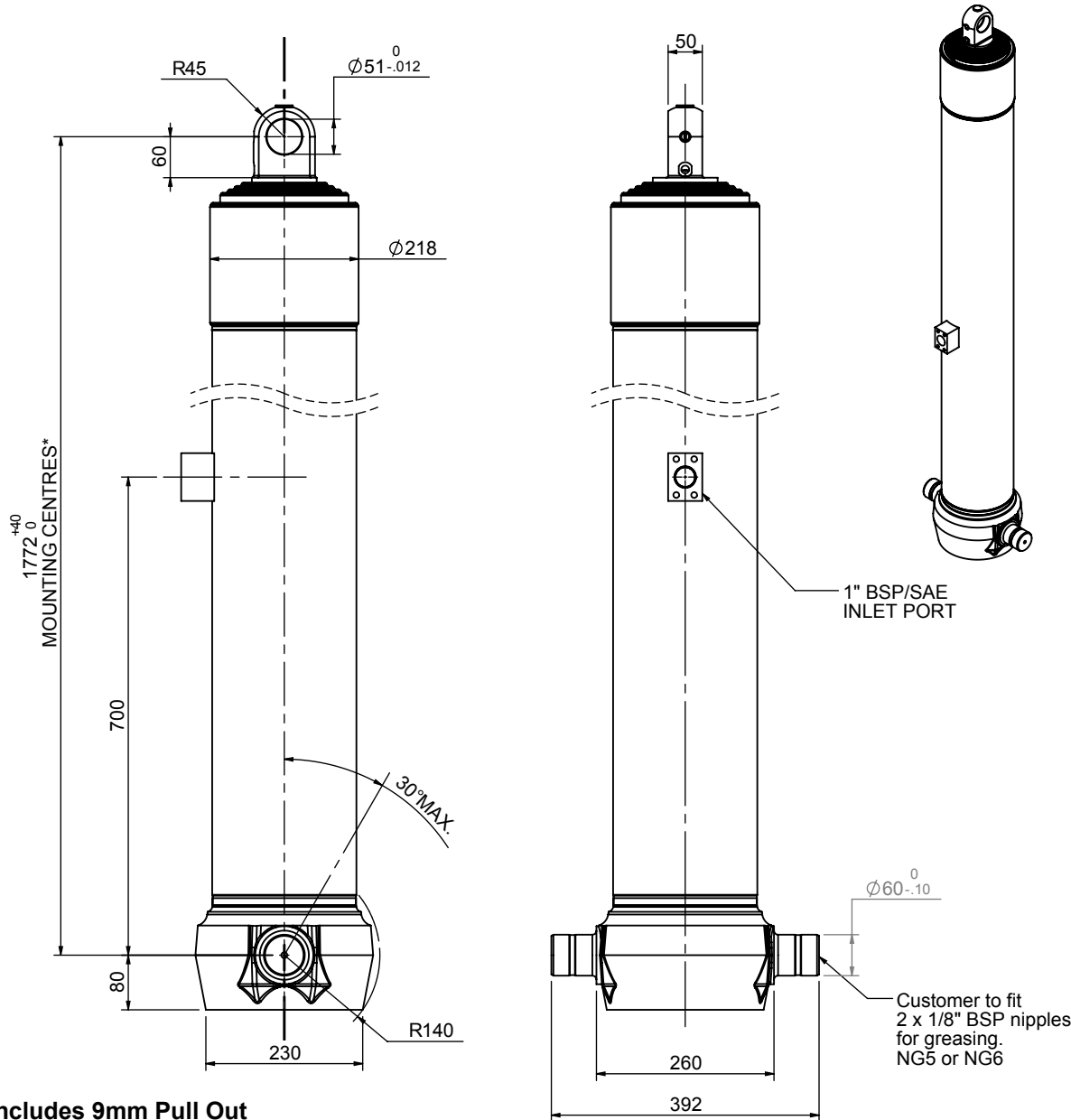

SPECIFICATION		RATED CAPACITY : 35-42 TONNES**		
Stage	Diameter	Length	Stroke	Swept Volume
-	-	-	-	-
0	211	1755	-	-
1	188	1720	1497	42
2	167	1720	1517	33
3	147	1720	1527	26
4	127	1720	1542	20
5	105	1722	1547	13
Final stroke reduced by	0	Total (+5/-10)	7630	134
Cylinder Mass (Kg)	303.56	Priming Volume	25	
Rated Pressure (Bar)	135	Total Volume (Litres)	159	
Maximum Pressure (Bar)	175	Max. first stage thrust	260 KN	

### \*\*TIPPING CAPACITY AT RATED PRESSURE

d = 0 ; r = 900

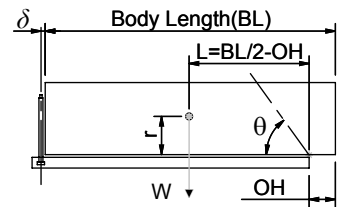

		BODY LENGTH (BL)			OH
		9250	9750	10250	
35	51°				150
38	52°	36	49°		450
42	55°	39	51°	37 48°	750

**For guidance only;**  
Higher Rated Pressures may be possible. To check your application, email Edbro plc at <applications@edbro.co.uk>

### NOTES

- If hydraulic pressure is used to limit overloading, the system relief valve must be set to the Rated Pressure unless agreed otherwise by Edbro
- The system relief valve can be set to Maximum Pressure if the load is limited by other means. See RATINGS page for advice
- This cylinder is for lifting purposes only and sload conditions must be avoided
- Cylinder is painted in primer paint to RAL5013
- See bracket options page BRKT01, BRKT02
- See installation instructions INSTALL01
- Use oil according to specification OIL01

\*Includes 9mm Pull Out Last Stage Chrome Plated



**Edbro plc**  
Nelson Street, Bolton, Lancashire BL3 2JJ UK  
Tel +44 (0) 1204 528888 Fax +44 (0) 1204 531957  
Email: postmaster@edbro.com Web: www.edbro.com

Technical Specifications are subject to change without notice  
Date Created/Updated: 14 September 2009 11:32:10  
Refer www.edbro.com to confirm latest specification  
All dimensions are in 'mm', unless otherwise stated