

Cylinder 5 stage front end with spherical eye

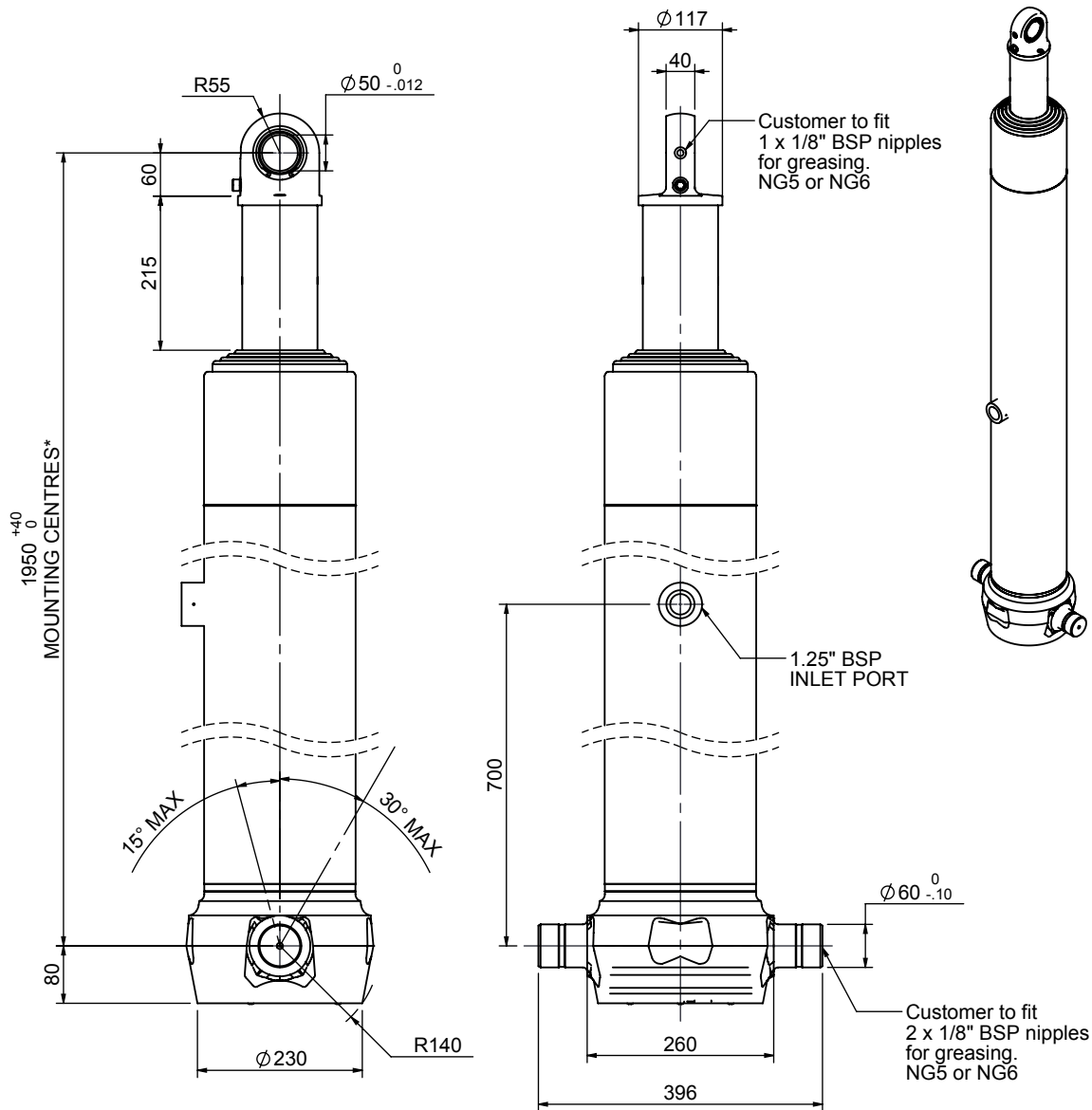

*Includes 9 mm Pull Out.
All Stages Chrome Plated

CS180S57483B70A09C

SPECIFICATION		TIPPING CAPACITY : 28-34 TONNES***		
Stage	Diameter	Length	Stroke	Swept Volume
-	-	-	-	-
0	211	1725	-	-
1	188	1690	1467	41
2	167	1690	1487	33
3	147	1690	1497	25
4	127	1690	1512	19
5	105	1890	1517	13
Total (+5/-10)			7480	131
Final stroke reduced by	0	Priming Volume		26
Cylinder Mass (Kg)	300	Total Volume (Litres)		157
Maximum Pressure (Bar)	190	Max. first stage thrust		265 KN

***TIPPING CAPACITY AT WORKING PRESSURE

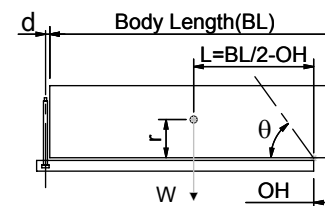

BODY LENGTH (BL)						OH
9500		10000		10500		
29	48°	28	45°			150
31	50°	30	47°	29	44°	450
34	52°	32	49°	30	46°	750

d = 0; r = 900; Working Pressure 120 bar

For guidance only;

Higher working pressures and tipping capacities may be possible.

To check your application email - applications@edbro.co.uk

NOTES

1. This cylinder is for lifting purposes only and side load conditions should be avoided
2. Cylinder is painted in primer paint to RAL5013
3. Refer to www.edbro.com for:-
 - Bracket details
 - Installation instructions that must be observed
 - Correct oil selection
 - An explanation of tipping capacity

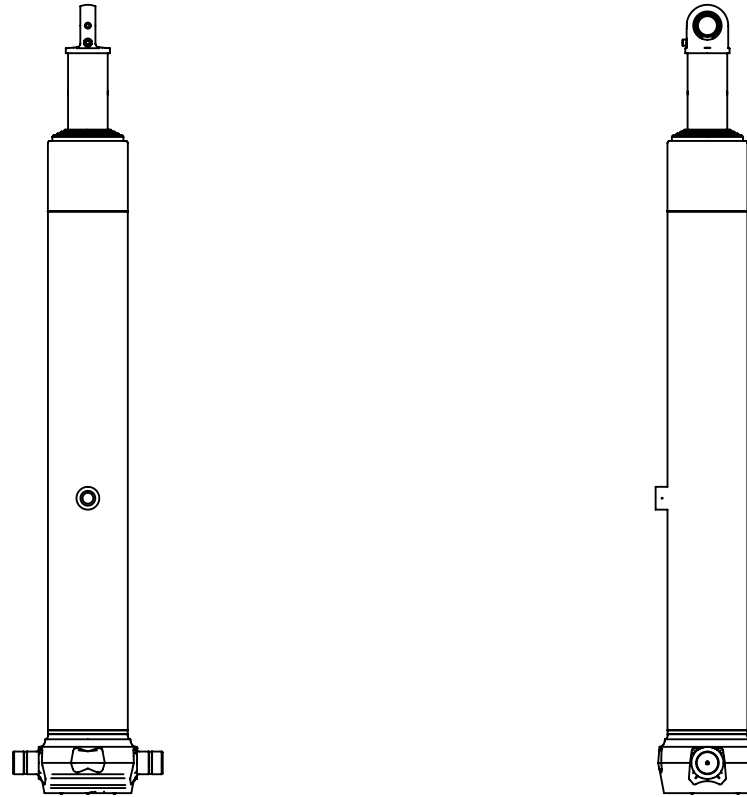

CS180S57483B70A09C