

Cylinder 5 stage front end with outer cover

** ALLOW 50mm TO REMOVE CAP FOR SERVICING

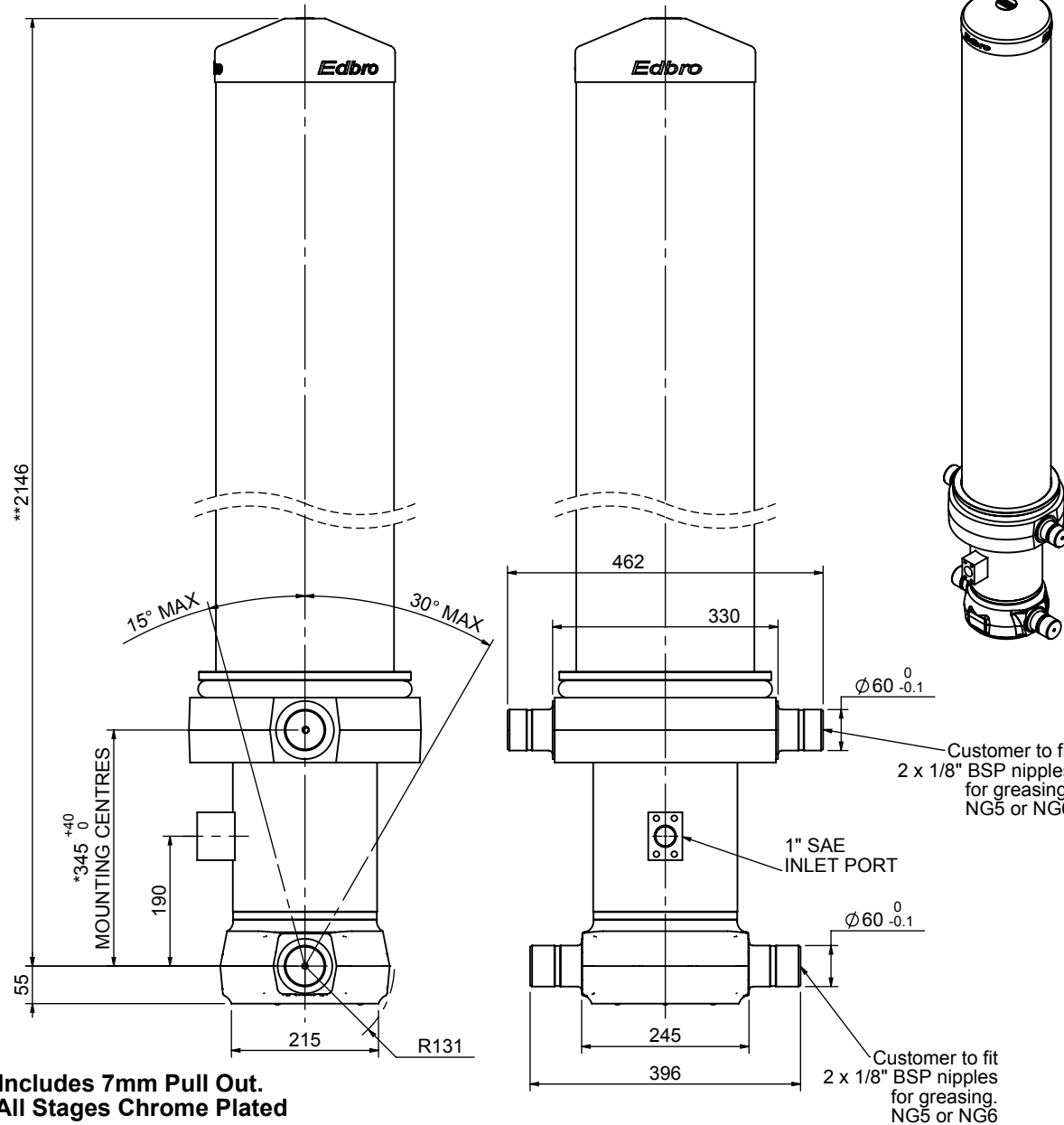

*Includes 7mm Pull Out.
All Stages Chrome Plated

CS18L059233S19A11C

SPECIFICATION TIPPING CAPACITY : 30-38 TONNES***

Stage	Diameter	Length	Stroke	Swept Volume
OUTER COVER	261	1765	-	-
0	211	2075	-	-
1	188	2040	1820	51
2	167	2040	1837	40
3	147	2040	1847	31
4	127	2040	1862	24
5	105	2040	1867	16
Total (+5/-10)			9233	162
Final stroke reduced by	0	Priming Volume		29.8
Cylinder Mass (Kg)	422	Total Volume (Litres)		191.8
Maximum Pressure (Bar)	190	Max. first stage thrust		200 KN

***TIPPING CAPACITY AT WORKING PRESSURE

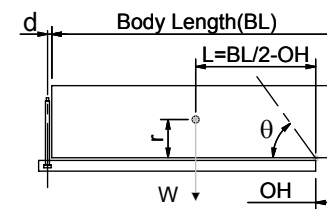

BODY LENGTH (BL)						OH
10500		11000		11500		
33	52°	31	49°	30	47°	150
35	54°	33	51°	32	48°	450
38	55°	35	52°	34	50°	750

d = 229; r = 900; Working Pressure 120 bar

For guidance only;

Higher working pressures and tipping capacities may be possible.

To check your application email - applications@edbro.co.uk

NOTES

1. This cylinder is for lifting purposes only and side load conditions should be avoided
2. Cylinder is painted in primer paint to RAL5013
3. Refer to www.edbro.com for:-
 - Bracket details
 - Installation instructions that must be observed
 - Correct oil selection
 - An explanation of tipping capacity

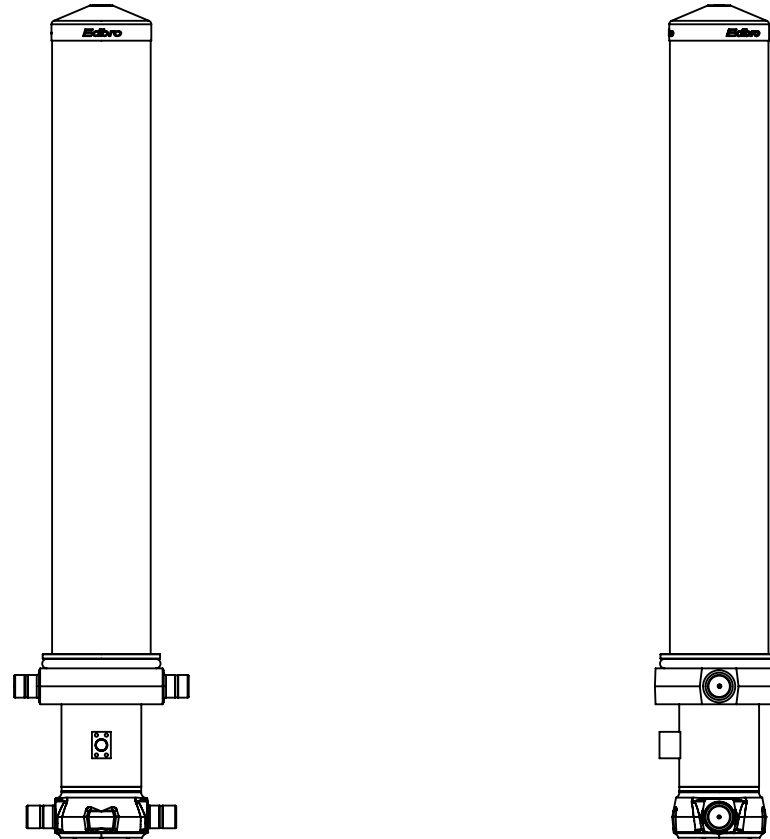

CS18L059233S19A11C