

Cylinder 5 stage front end with outer cover

****ALLOW 50mm TO REMOVE CAP FOR SERVICING**

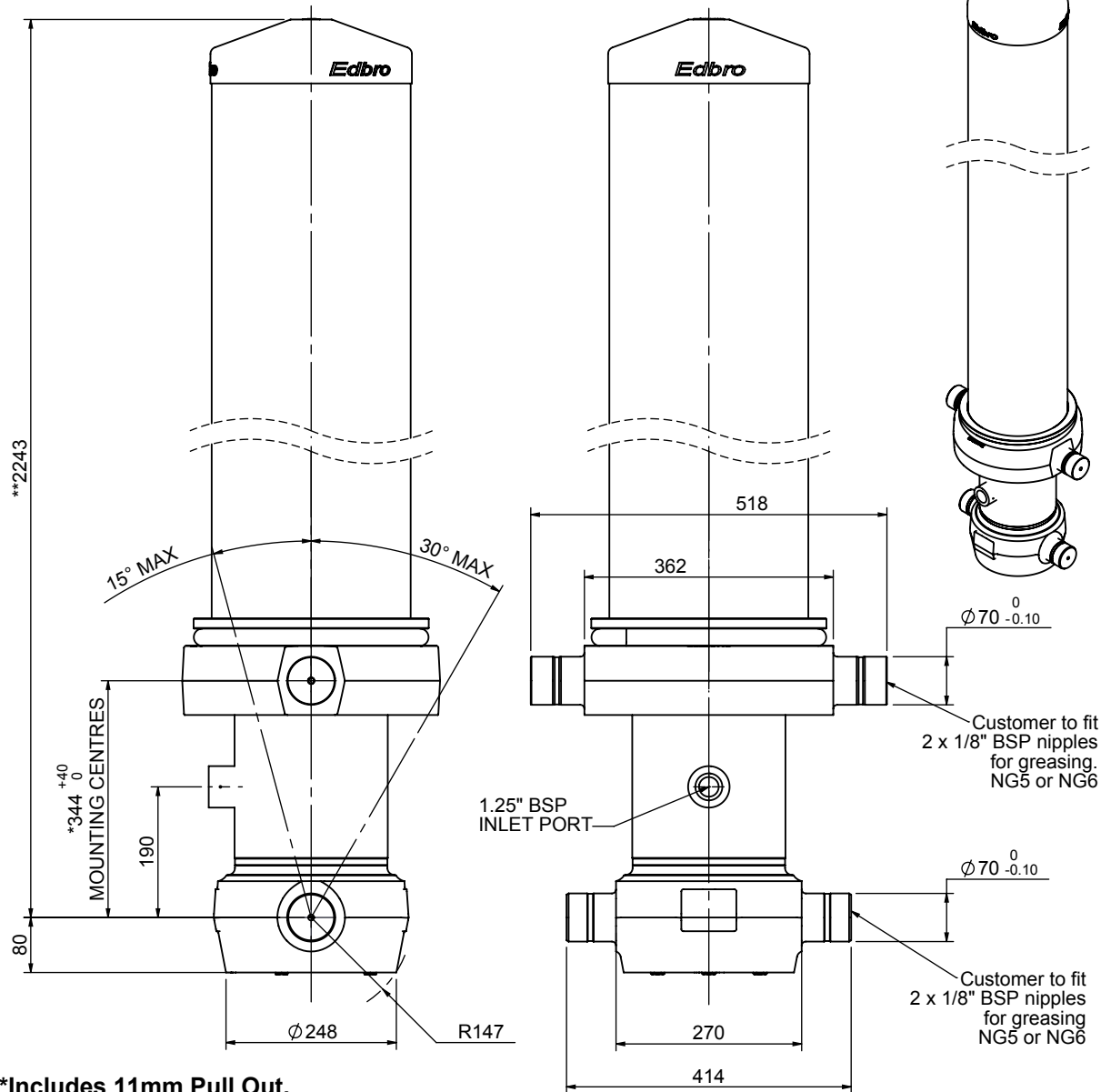

***Includes 11mm Pull Out.
All Stages Chrome Plated**

CS190059678B19A11C

SPECIFICATION

TIPPING CAPACITY : 37-42 TONNES***

Stage	Diameter	Length	Stroke	Swept Volume
OUTER COVER	289	1835	-	-
0	223	2178	-	-
1	198	2140	1906	59
2	176	2140	1927	47
3	155	2140	1937	37
4	136	2140	1947	28
5	117	2140	1962	21
Total (+5/-10)			9679	192
Final stroke reduced by	0	Priming Volume		38
Cylinder Mass (Kg)	495	Total Volume (Litres)		230
Maximum Pressure (Bar)	190	Max. first stage thrust		350 KN

***TIPPING CAPACITY AT WORKING PRESSURE

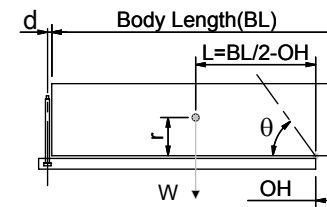

BODY LENGTH (BL)						OH
11000	11500	12000				
37	52°				150	
39	54°	37	51°	36	49°	450
42	55°	40	52°	38	50°	750

$d = 229$; $r = 900$; Working Pressure 110 bar

For guidance only;

Higher working pressures and tipping capacities may be possible.

To check your application email - applications@edbro.co.uk

NOTES

1. This cylinder is for lifting purposes only and side load conditions should be avoided
2. Cylinder is painted in primer paint to RAL5013
3. Refer to www.edbro.com for:-
 - Bracket details
 - Installation instructions that must be observed
 - Correct oil selection
 - An explanation of tipping capacity

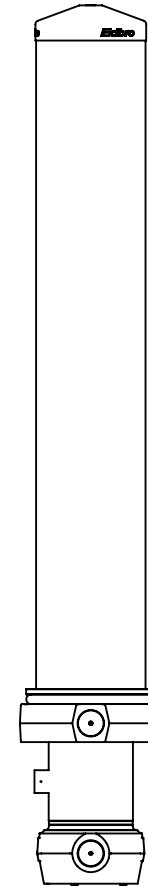
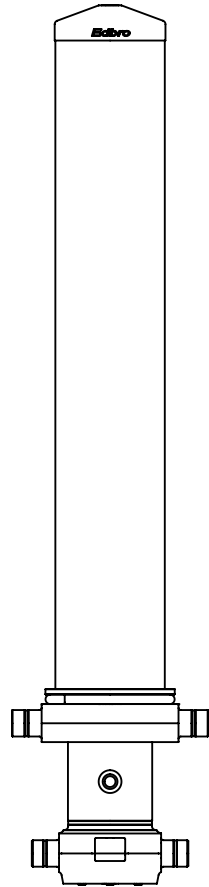

CS190059678B19A11C