

# Cylinder 5 stage front end with plain eye

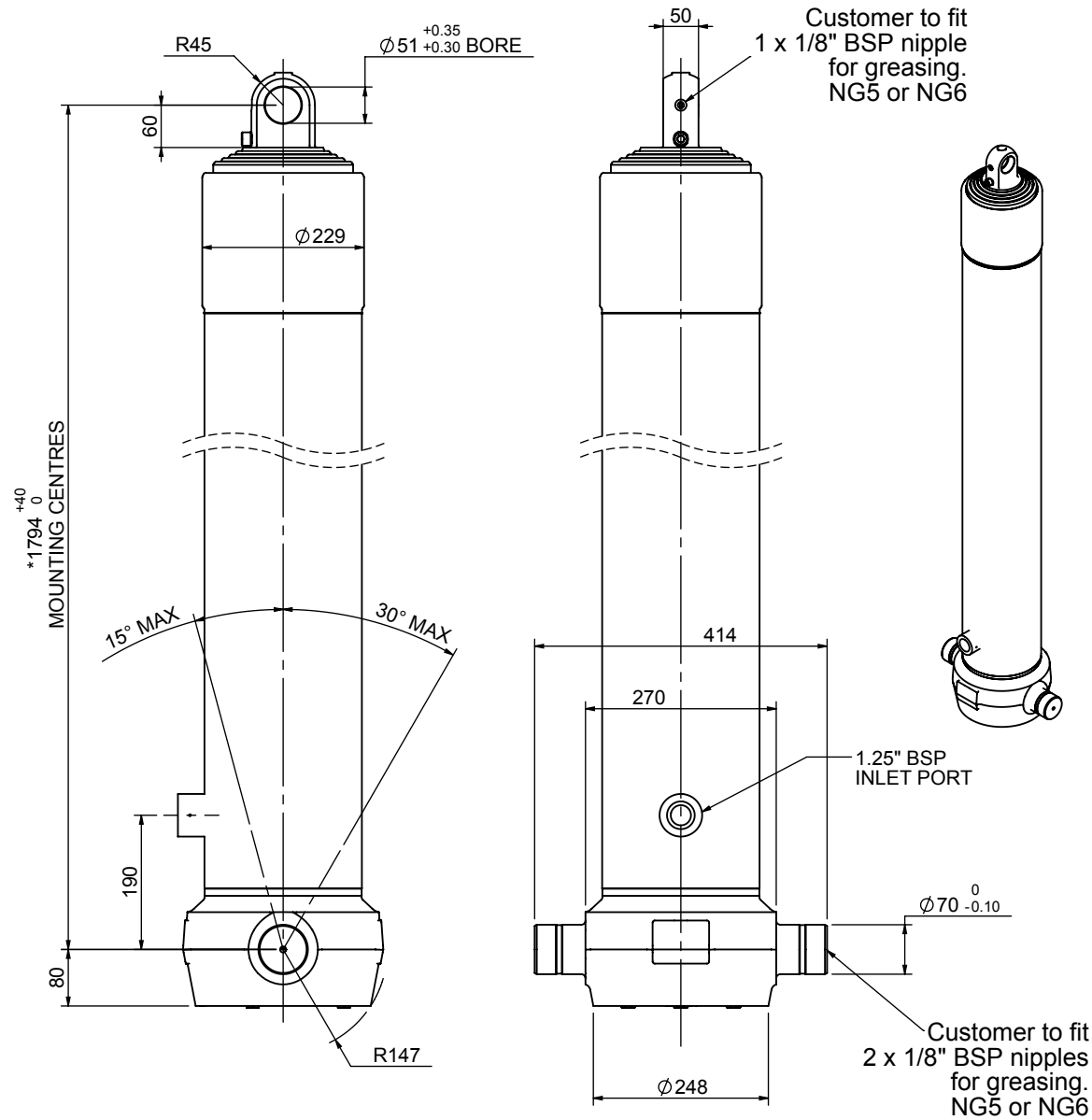

# CS190E57678B19A01

SPECIFICATION		TIPPING CAPACITY : 27-35 TONNES***		
Stage	Diameter	Length	Stroke	Swept Volume
-	-	-	-	-
0	223	1778	-	-
1	198	1740	1504	46
2	176	1740	1527	37
3	155	1740	1537	29
4	136	1740	1547	22
5	117	1740	1562	17
Total (+5/-10)			7677	151
Final stroke reduced by	0	Priming Volume		30
Cylinder Mass (Kg)	319	Total Volume (Litres)		181
Maximum Pressure (Bar)	190	Max. first stage thrust		350 KN

### \*\*\*TIPPING CAPACITY AT WORKING PRESSURE

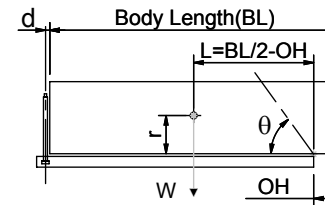

BODY LENGTH (BL)						OH
9250	9750	10250				
29	51°	28	48°	27	45°	150
32	53°	30	50°	28	47°	450
35	55°	32	52°	30	49°	750

d = 0; r = 900; Working Pressure 90 bar

### For guidance only;

Higher working pressures and tipping capacities may be possible.

To check your application email - [applications@edbro.co.uk](mailto:applications@edbro.co.uk)

### NOTES

1. This cylinder is for lifting purposes only and side load conditions should be avoided
2. Cylinder is painted in primer paint to RAL5013
3. Refer to [www.edbro.com](http://www.edbro.com) for:-
  - Bracket details
  - Installation instructions that must be observed
  - Correct oil selection
  - An explanation of tipping capacity

\*Includes 10mm Pull Out. Last Stage Chrome Plated



**Edbro plc**  
 Nelson Street, Bolton, England, BL3 2JJ  
 Tel +44 (0) 1204 528888 Fax +44 (0) 1204 531957  
 Email: [postmaster@edbro.com](mailto:postmaster@edbro.com) Web: [www.edbro.com](http://www.edbro.com)

Technical Specifications are subject to change without notice  
 Date Created/Updated: 16 July 2012  
 Refer [www.edbro.com](http://www.edbro.com) to confirm latest specification  
 All dimensions are in 'mm', unless otherwise stated

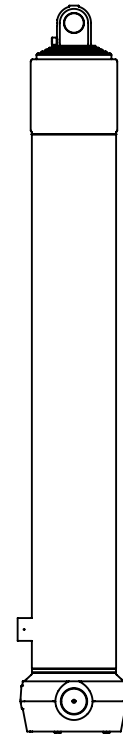
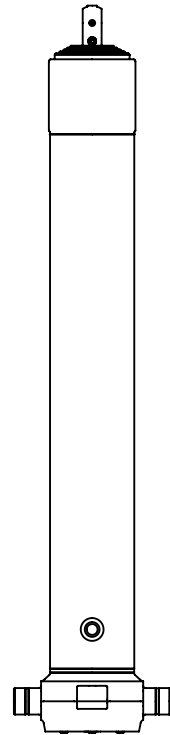

CS190E57678B19A01