

**Valve: Multifunctional Hydraulic Valve - CTD250/60P160**

- \* Multifunctional hydraulic valve with auxiliary valves with 1 double acting section
- \* Part no: CTD250/60P160
- \* Main valve flow rate = 250l/min
- \* Max working pressure = 320bar
- \* Auxiliary valve flow rate = 60l/min
- \* Max working pressure = 320bar

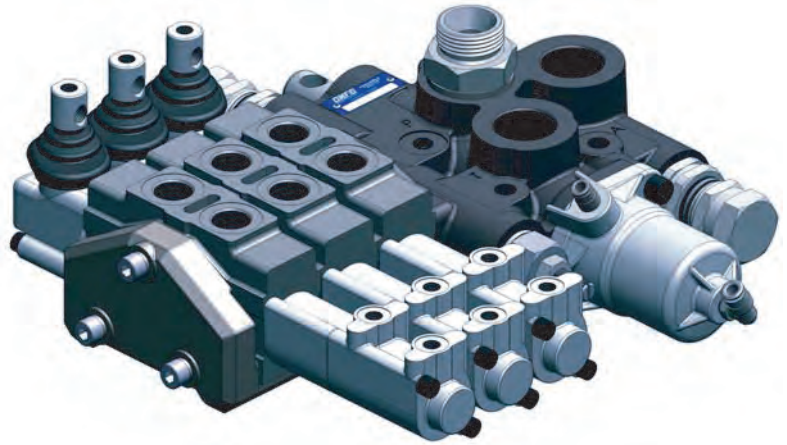

TECHNICAL FEATURES OF MAIN VALVE		
Flow rate	l/min.	250
Max. working pressure	bar	320
Working temperature		-15+110°C
Oil viscosity		12 - 100 cSt
Oil filtering		< 25 μm
Standard pressure setting	bar	160
Max. pneumatic pressure	bar	12

TECHNICAL FEATURES OF AUXILIARY VALVES		
Flow rate	l/min.	60
Max. working pressure	bar	320
Working temperature		-15+110°C
Oil viscosity		12 - 100 cSt
Oil filtering		< 25 μm
Max. pneumatic pressure	bar	12

**Tipping valve pressure drops**

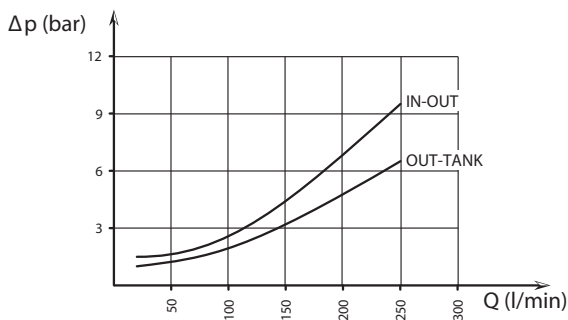

All dimensions are given in mm unless otherwise stated. Technical Specifications are subject to change without notice.

Valve: Multifunctional Hydraulic Valve

**DIMENSIONS**

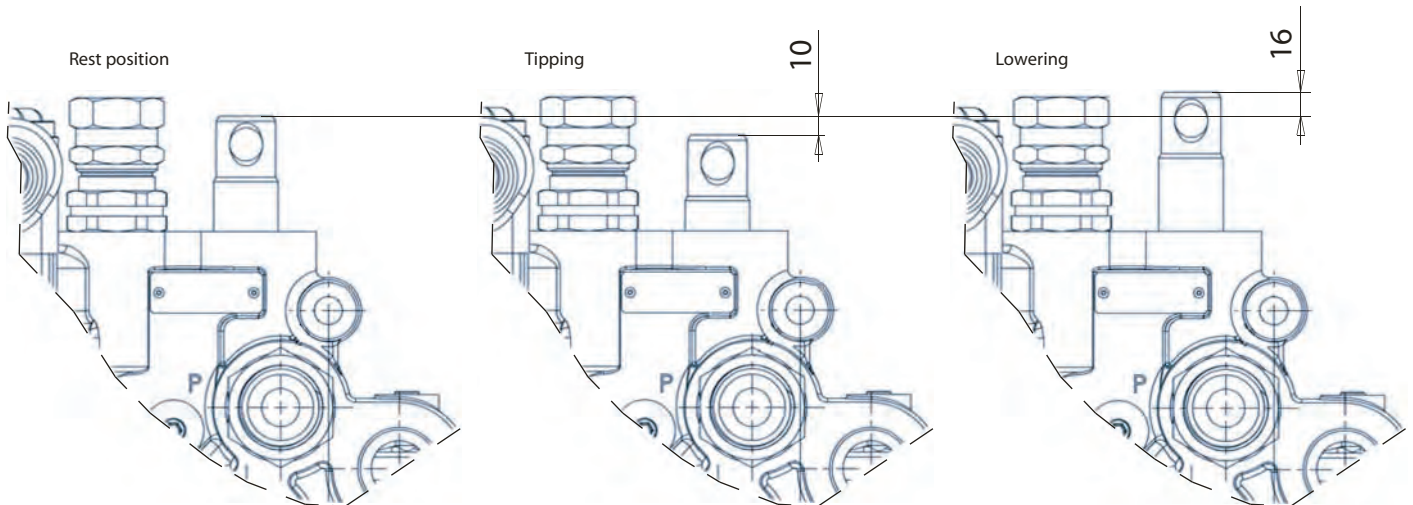
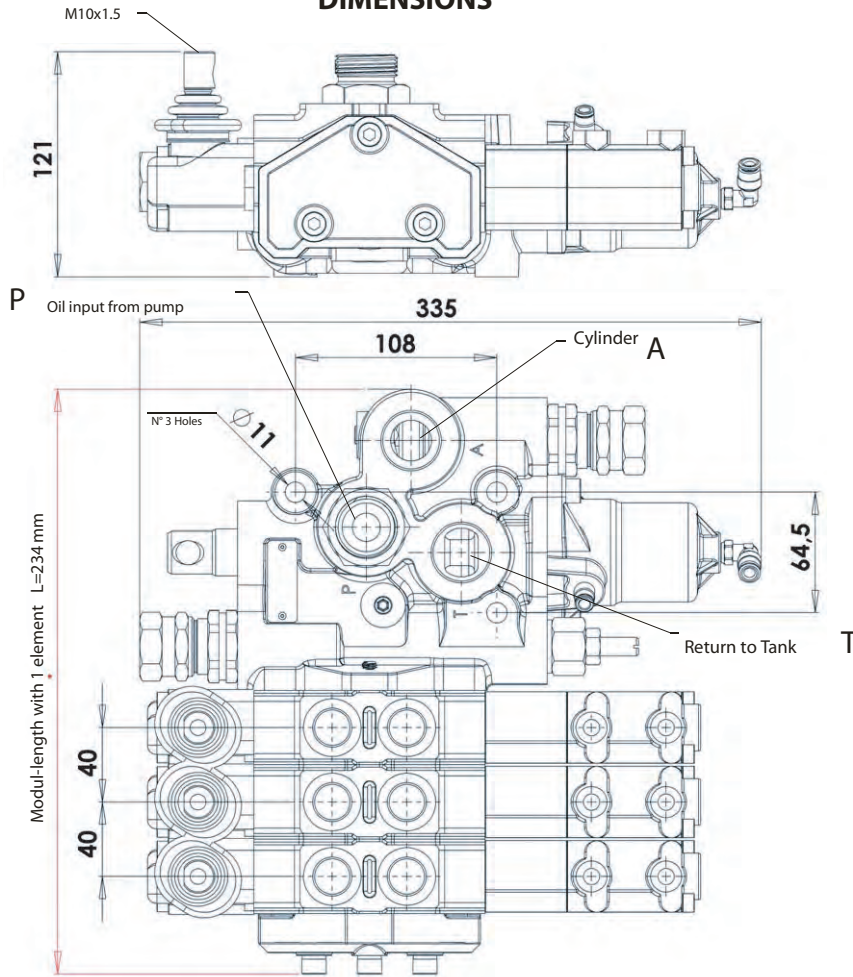

All dimensions are given in mm unless otherwise stated. Technical Specifications are subject to change without notice.