

Directional Control Valve: Dual Tipper Operation - CTD250M100P140-300

- * Two-spool control valve
- * For applications including cranes, tippers & refuse trucks

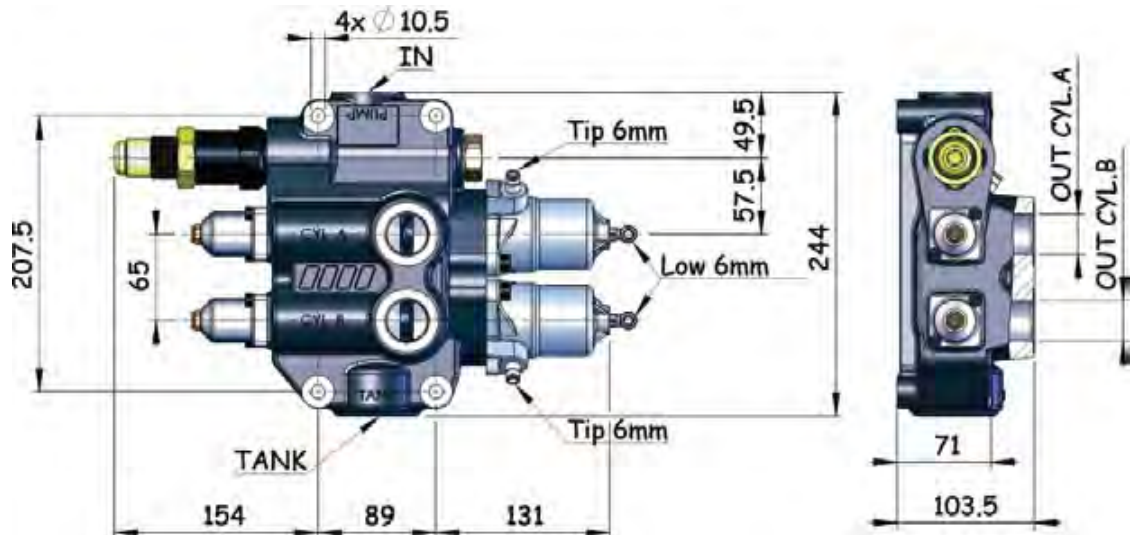

CTD250M100P140-300 Technical Specification	
Inlet port	1" BSP
Tank port	1¼" BSP
Outlet ports (A & B)	1" BSP
Weight	25kg
Standard pressure setting	140 bar
Maximum pressure setting	300 bar
Flow rate	250 l/min



Hydraulic Valves

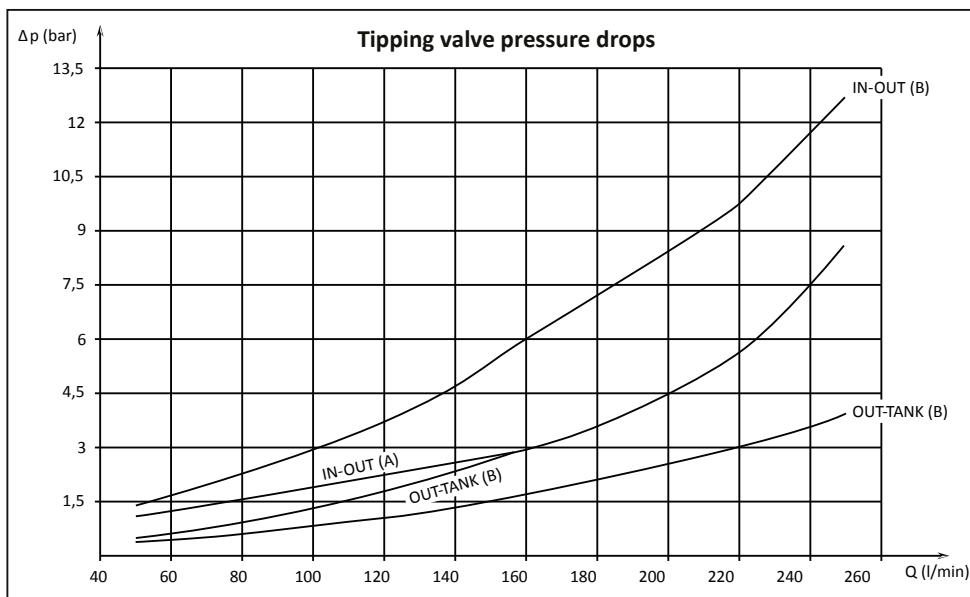

All dimensions are given in mm unless otherwise stated. Technical Specifications are subject to change without notice.

Directional Control Valve: Dual Tipper Operation - CTD250M100P140-300

Spare Parts:

The following spare parts are available from Edbro for the CTD250M100P140-300 control valve.

* Seal kit **SKCTD250** (contains items 7, 11, 13, 15, 20, 25, 26, 28 & 31 as shown )

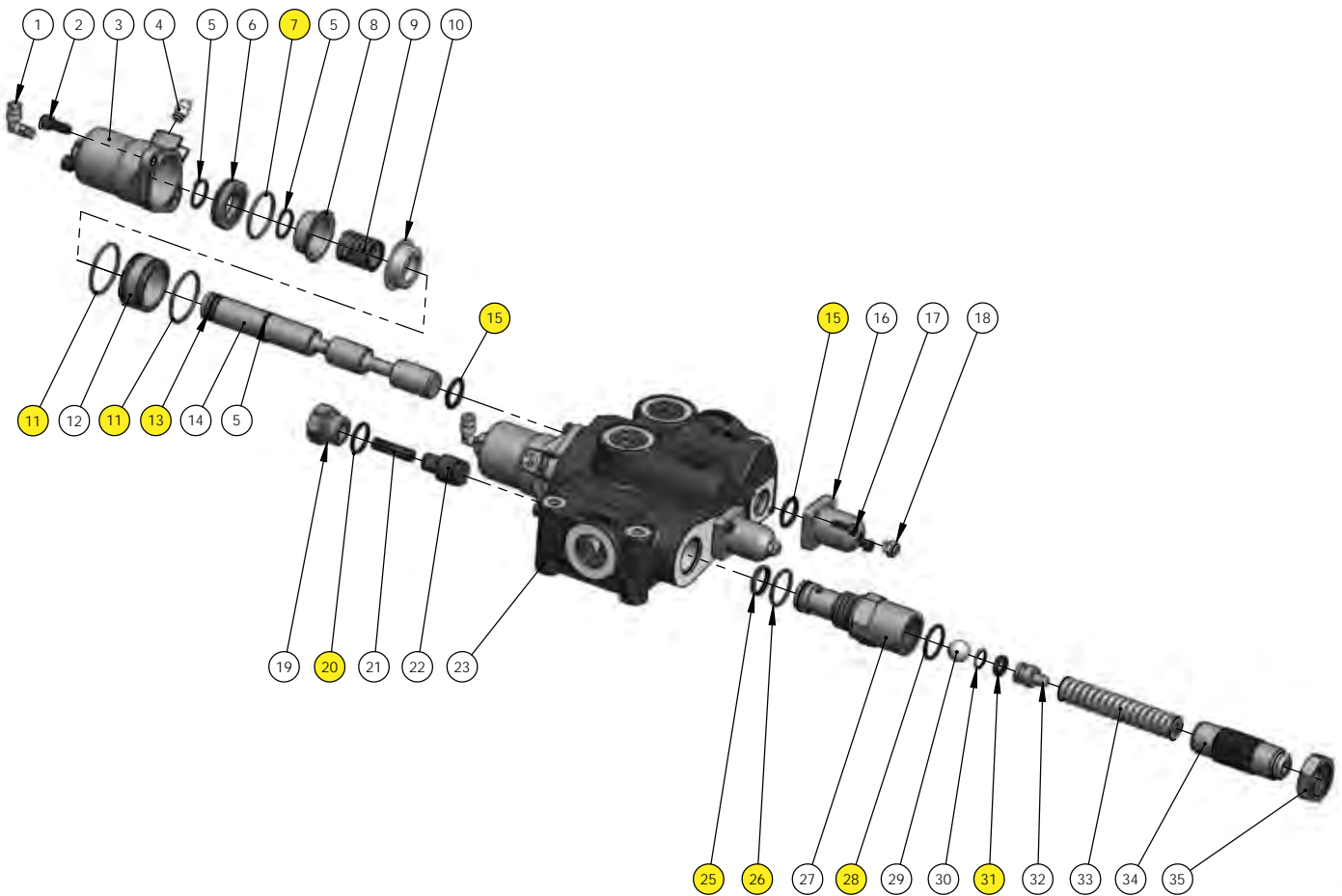

All dimensions are given in mm unless otherwise stated. Technical Specifications are subject to change without notice.