

Cylinder 4 stage front end with outer cover

****ALLOW 50mm TO REMOVE CAP FOR SERVICING**

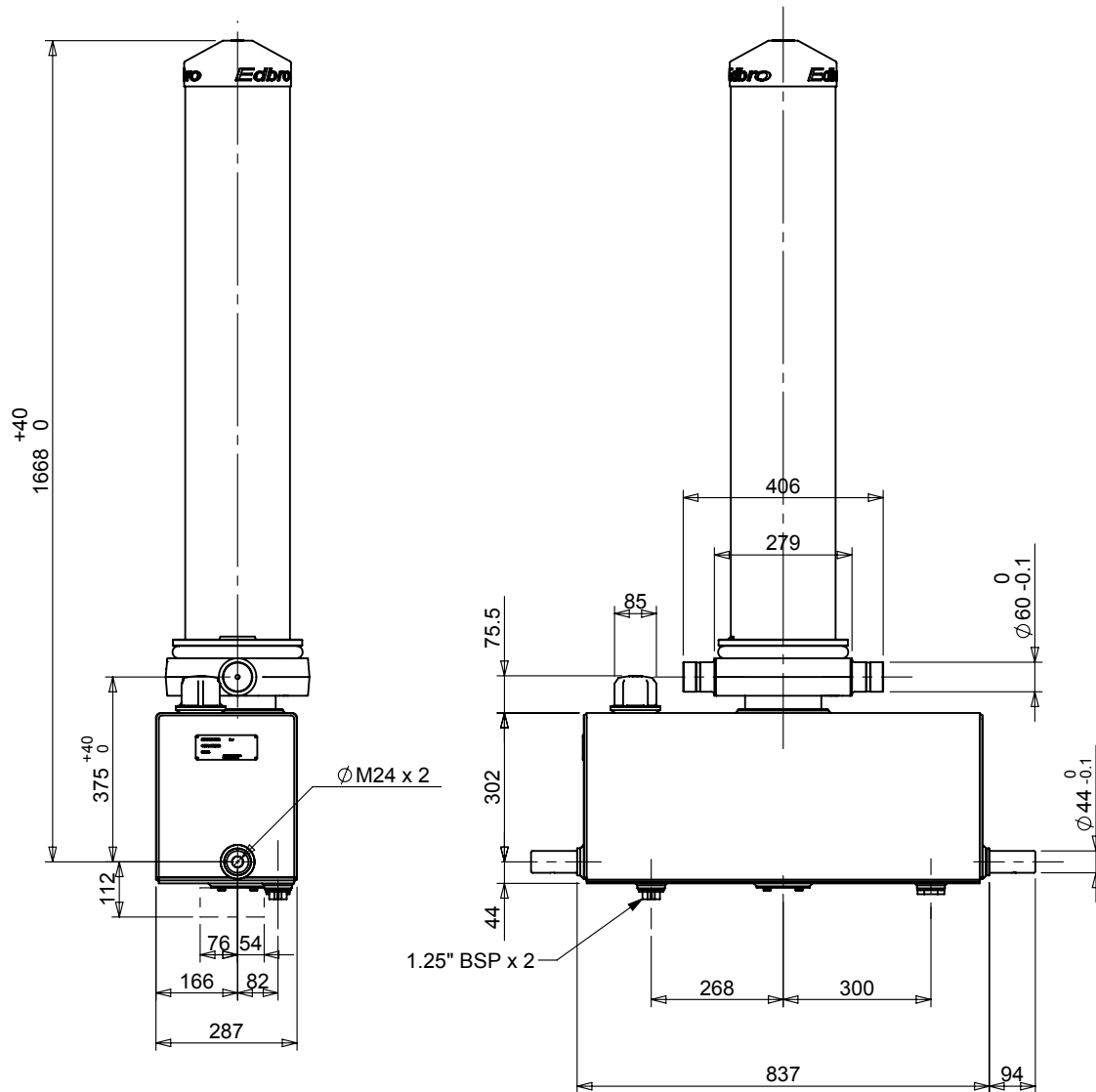

***Includes 9mm Pull Out.**

CX1300405441B381

SPECIFICATION		TIPPING CAPACITY : 19-28 TONNES***		
Stage	Diameter	Length	Stroke	Swept Volume
OUTER COVER	213	1250	-	-
0	155	1520	-	-
1	136	1540	1344	20
2	117	1540	1362	15
3	98	1540	1367	10
4	79	1560	1372	7
Total (+5/-10)			5445	52
Final stroke reduced by	0	Priming Volume		13.6
Cylinder Mass (Kg)	259	Total Volume (Litres)		65.6
Maximum Pressure (Bar)	150	Oil Tank Capacity (L)		58

***TIPPING CAPACITY AT WORKING PRESSURE

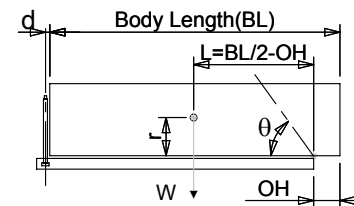

BODY LENGTH (BL)						OH
6750		7250		7750		
21	47	20	44°	19	41°	150
24	50	22	46	20	43	450
28	52	25	48	23	44	750

$d = 0$; $r = 900$; Working Pressure 135 bar

For guidance only;

Higher working pressures and tipping capacities may be possible.
To check your application email - applications@edbro.co.uk

NOTES

1. This cylinder is for lifting purposes only and side load conditions should be avoided
2. Cylinder is painted in primer paint to RAL5013
3. Refer to www.edbro.com for;-
 - Bracket details
 - Installation instructions that must be observed
 - Correct oil selection
 - An explanation of tipping capacity