

- 125 cm³/rev output flow
- Medium pressure (150 bar mwp)
- Compact size for easy installation
- Ideal for close coupled PTO mounting
- 4 - Hole ISO7653 Mounting flange
- Bronze thrust plates for maximum durability
- Bi-Directional Pump
- Optional output port

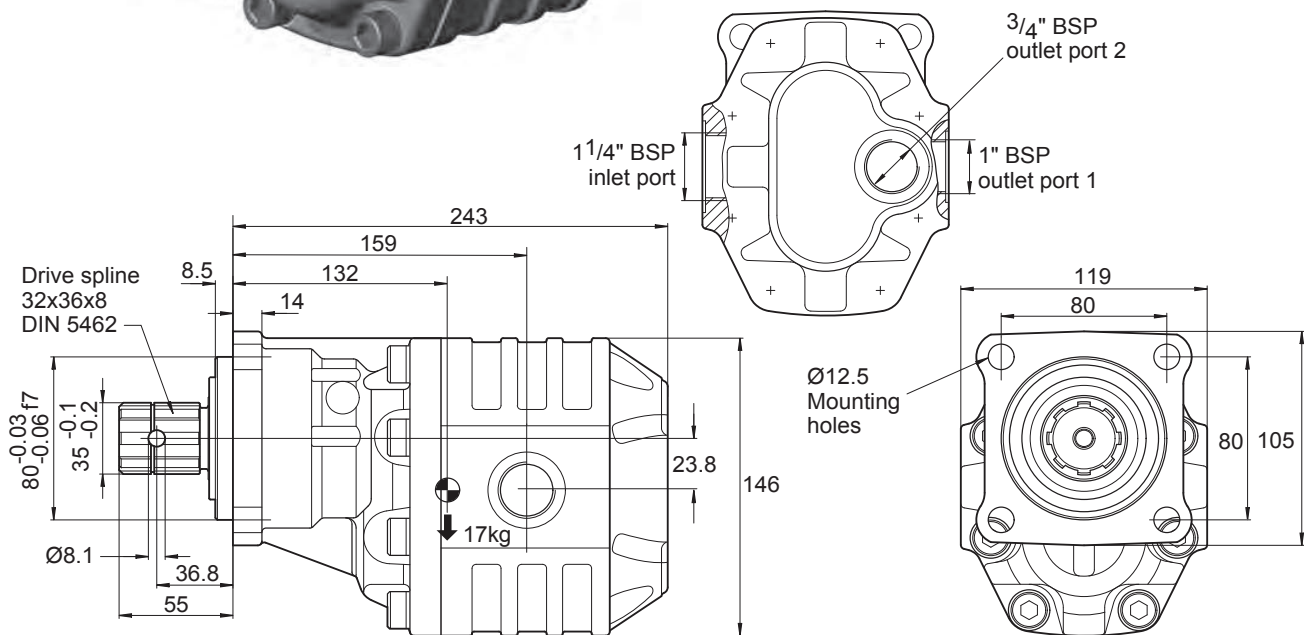

PERFORMANCE

Displacement	cm ³ /rev	125
Max. Working Pressure	bar	150
Peak Pressure	bar	180

Pump Maximum Speeds, in rpm:

	Suction Size	
	1.5"	2"
Continuous	1300	1500
Intermittent	2300	2500

OIL & FILTRATION

- This pump is designed for low pressure, intermittent use, tipper systems without filtration.
- The oil should be a good quality hydraulic oil to ISO 6743/4 HM32 for -15° to +27°C working temperature.
- For extended life or for higher duty applications, 25µm absolute return line filtration is recommended.
- Oil cleanliness to be maintained to ISO 4406 class 19/16.
- Oil should be replaced annually.

PUMP ROTATION

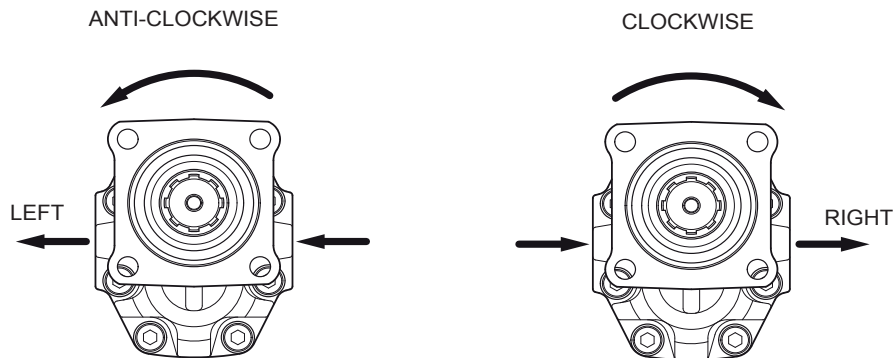

- Pumps can be supplied to suit the rotation required
- If rotation is to be reversed, refer to instructions supplied with the kit