

PTO - Pneumatic Clutch- PT184

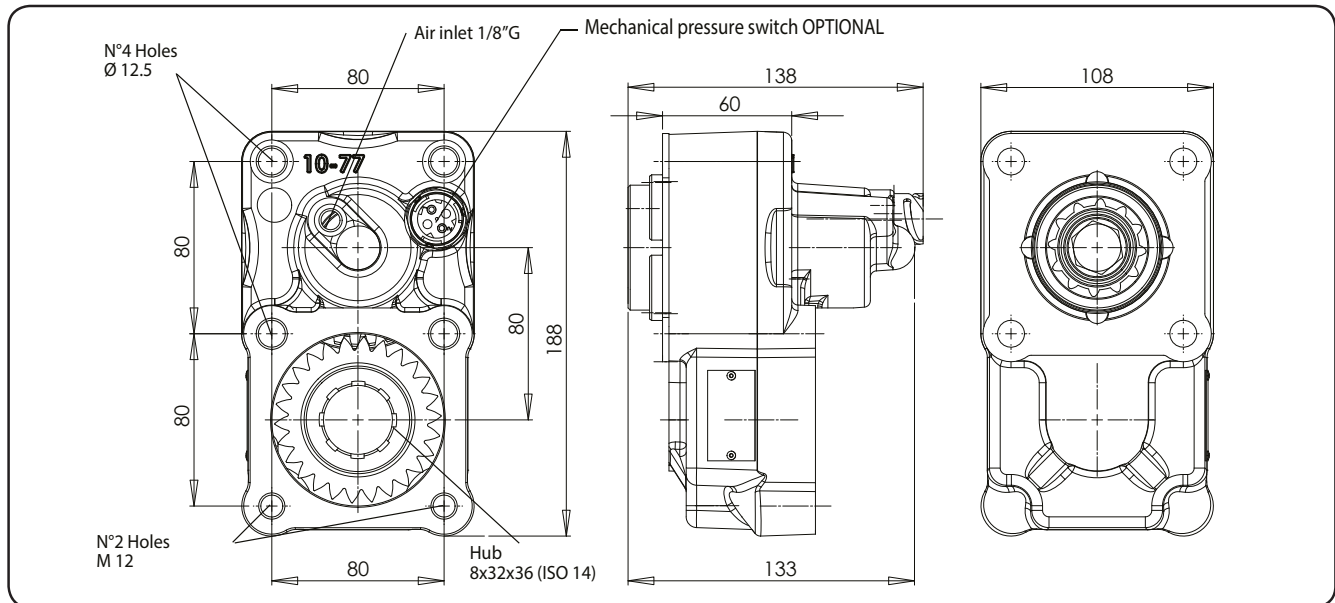
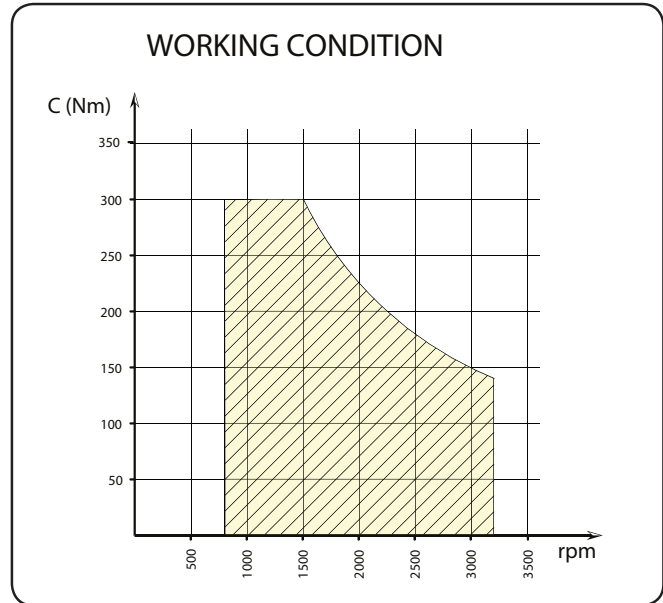
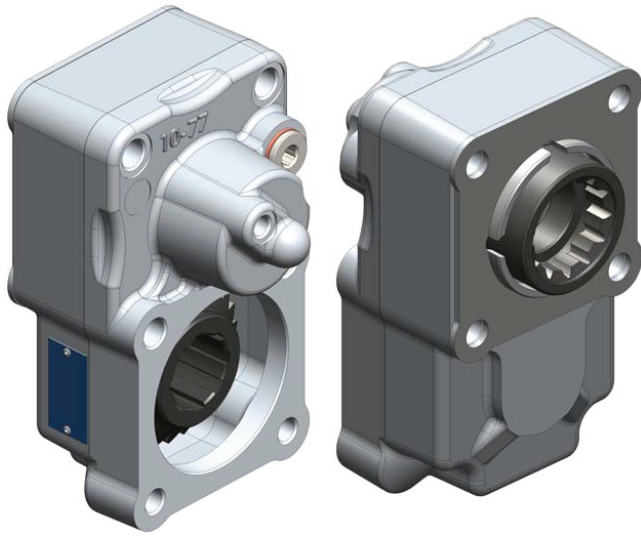

TECHNICAL SPECIFICATION:

Gearbox :	Volvo and ZF
Max torque :	300 Nm
Mounting side :	Rear
Output :	Rear
Rotation :	Anti-Clockwise
Weight:	11kg
Internal ratio:	= 1:1.35

All dimensions are given in mm unless otherwise stated. Technical Specifications are subject to change without notice.